



Simple Configuration Examples for the AX Series

for
the
Guaranteed
Network

Edition 1



Preface

This document briefly explains the configurations of the AX series.

The sample network in this document consists of multiple product series (AX6700S/AX6300S/AX3600S/AX2400S/AX1200S).

For the AX1200S series, we present configuration examples for the AX1230S series and explain any difference between the AX1200S series and AX1240S series by using notes.

For the details of configurations and commands, see the manual of each product.

As reference material, configuration text files are attached.

Related documents

· Product manuals of AX series (<http://www.alaxala.com/en/techinfo/manual/index.html>)

Notes on using this document

- It is forbidden to reprint or reproduce this document wholly or in part.
- Information in this document is subject to change without notice.
- The information in this document is based on the basic operations verified under the environment specified by ALAXALA and does not guarantee operations regarding functionality, performance, and reliability under all environment requirements. Please understand that this document is intended to help with system configuration for our products.
- Hardware devices and the versions of the OS used for creating this document consist of the following:

| Device | OS |
|---|------------------------------------|
| AX6700S: AX6708S (BCU-S1/BSU-LB/NK1G-24T) | Ver.10.8 |
| AX6300S: AX6304S (MSU-1A/MH1G-24T) | Ver.10.8 |
| AX3600S: AX3630S-48TW | Ver.10.8 |
| AX2400S: AX2430S-48T (1.1-1.3/1.11/2.5/2.6) | Ver.10.8 |
| : AX2430S-24T (1.4-1.10) | Ver.10.8 |
| AX1230S: AX1230S-24T2CA | Ver.1.4.B (Ver.1.3.F for 1.3 only) |
| AX1240S: AX1240S-24T2C | Ver.2.0 |

Export restrictions

If you export this guide, you must check and comply with all applicable laws, rules, and restrictions of Japan and any other countries, such as Japan's Foreign Exchange and Foreign Trade Law and U.S. export control laws and regulations.

Trademarks

- The ALAXALA name and logo are trademarks or registered trademarks of ALAXALA Networks Corporation.
- Ethernet is a trade name of Xerox Corporation in the United States.
- Other company and product names in this manual are trademarks or registered trademarks of their respective owners.

Conventions: The terms "Switch" and "switch"

The term Switch (upper-case "S") is an abbreviation for any or all of the following models:

- AX6700S/AX6600S/AX6300S series switch
- AX3600S, AX2400S series switch
- AX2500S series switch
- AX1200SA series switch

The term switch (lower-case "s") might refer to a Switch, another type of switch from the current vendor, or a switch from another vendor. The context decides the meaning.

Contents

| | |
|--|-----|
| 1. Configuration Examples of L2 Functionalities..... | 4 |
| 1.1 VLAN tunneling..... | 4 |
| 1.2 Tag conversion | 7 |
| 1.3 PVST+ | 10 |
| 1.4 Load balancing using PVST+ | 14 |
| 1.5 Root guard functionality of spanning trees..... | 22 |
| 1.6 IGMP snooping | 28 |
| 1.7 QoS..... | 33 |
| 1.8 DHCP snooping | 42 |
| 1.9 L2 loop detection..... | 47 |
| 1.10 Storm control..... | 52 |
| 1.11 Rings | 60 |
| 2. Configuration Examples of L3 Functionalities..... | 67 |
| 2.1 RIP | 67 |
| 2.2 RIP filters..... | 74 |
| 2.3 OSPF..... | 78 |
| 2.4 OSPF multiple areas..... | 85 |
| 2.5 VRRP | 91 |
| 2.6 GSRP (L2/L3 linkage) | 98 |
| 3. Configuration Examples of Other Network Functionalities | 110 |
| 3.1 DHCP | 110 |
| 3.2 NTP | 115 |
| Appendix 1. Configuration Files..... | 118 |

1. Configuration Examples of L2 Functionalities

1.1 VLAN tunneling

This section describes a configuration example that aggregates, or *tunnels*, multiple VLANs into another VLAN.

[Configuration figure]

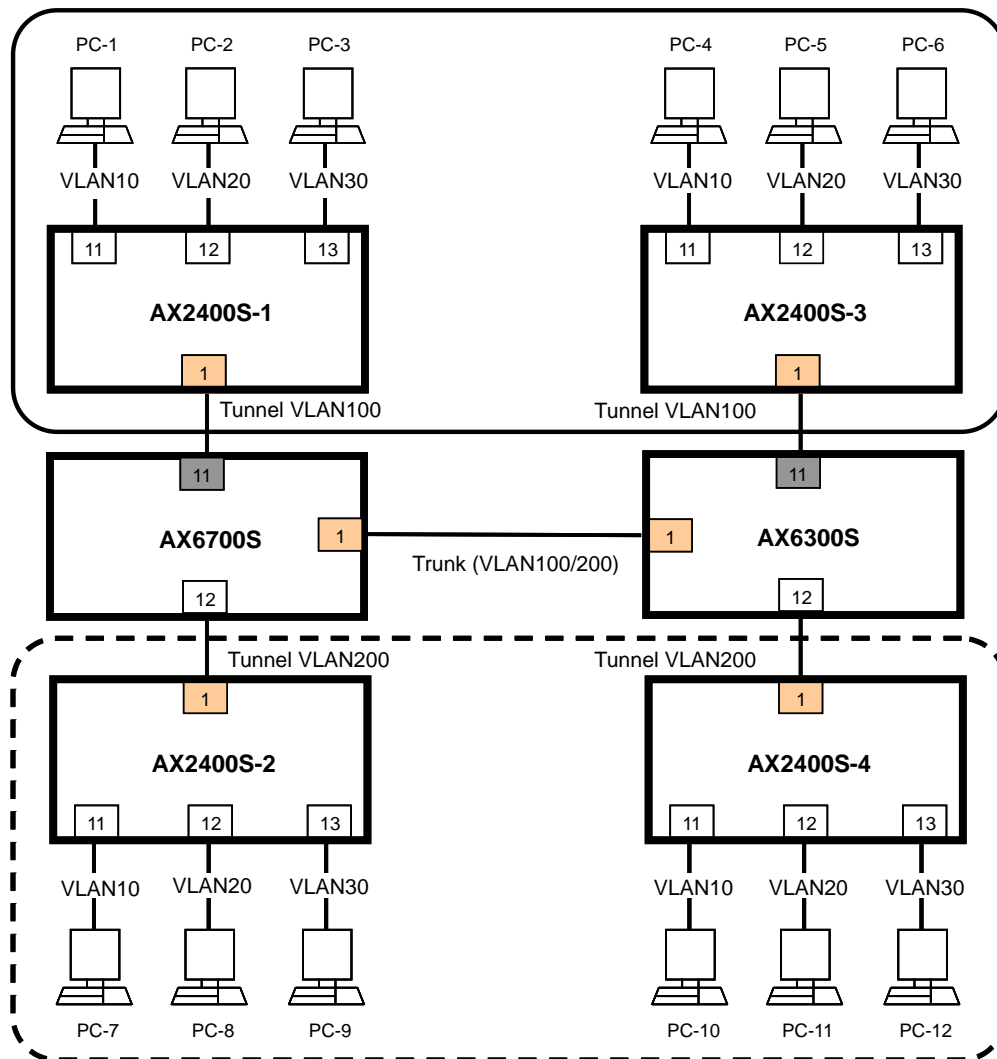

[Explanation of the configuration figure]

For the switch AX6700S, VLANs 10, 20, and 30 of the switch AX2400S-1 are tunneled into VLAN 100. In the same way, VLANs 10, 20, and 30 of the switch AX2400S-2 are tunneled into VLAN 200. Though not configured in this example, the VLAN that aggregates other VLANs will be passed to the switch AX6300S as a trunk.

[Notes]

This example describes only the configurations with the switch AX6700S and the switches AX2400S-1/2. You also need to configure the switch AX6300S and the switches AX2400S-3/4.

Configuration key points

- Aggregate multiple VLANs from the switch AX2400S-1 on port 1/11 of the switch AX6700S.
- Aggregate multiple VLANs from the switch AX2400S-2 on port 1/12.

[Configuration examples]

● AX6700S

```
1.(config)# vlan 100,200
   (config-vlan)# exit

2.(config)# interface gigabitethernet 1/1
   (config-if)# switchport mode trunk
   (config-if)# switchport trunk allowed vlan 100,200
   (config-if)# exit

3.(config)# interface gigabitethernet 1/11
4.(config-if)# switchport mode dot1q-tunnel
5.(config-if)# switchport access vlan 100
   (config-if)# exit

6.(config)# interface gigabitethernet 1/12
7.(config-if)# switchport mode dot1q-tunnel
8.(config-if)# switchport access vlan 200
   (config-if)# exit
```

1. Creates VLAN 100 and VLAN 200 for tunneling other VLANs
2. Sets VLAN 100 and VLAN 200 as trunk ports
3. Sets port 1/11 as a port that accepts the trunk from AX2400S-1
4. Sets port 1/11 as a trunk port
5. Sets VLAN 100 as the tunneling VLAN
6. Sets port 1/12 as a port that accepts the trunk from AX2400S-2
7. Sets port 1/12 as a trunk port
8. Sets VLAN 200 as the tunneling VLAN

● AX2400S-1/AX2400S-2

```
1.(config)# vlan 10,20,30
   (config-vlan)# exit

2.(config)# interface gigabitethernet 0/1
   (config-if)# media-type rj45
   (config-if)# switchport mode trunk
   (config-if)# switchport trunk allowed vlan 10,20,30
   (config-if)# exit

3.(config)# interface gigabitethernet 0/11
   (config-if)# switchport mode access
   (config-if)# switchport access vlan 10
   (config-if)# exit

   (config)# interface gigabitethernet 0/12
   (config-if)# switchport mode access
   (config-if)# switchport access vlan 20
   (config-if)# exit

   (config)# interface gigabitethernet 0/13
   (config-if)# switchport mode access
   (config-if)# switchport access vlan 30
   (config-if)# exit
```

1. Creates VLAN 10, VLAN 20, and VLAN 30 that will be trunked
2. Sets VLAN 10, VLAN 20, and VLAN 30 that will be trunked, to ports 0/1 unchanged as trunk ports
3. Sets VLAN 10, VLAN 20, and VLAN 30 to ports 0/11, 0/12, and 0/13, respectively

[Operation example]

● VLAN status

```

AX6708S# show port vlan
Date 2009/01/26 14:01:42 JST
Port Counts: 24
Port Name          Status Type          VLAN
1/ 1 geth1/1       down  Trunk           100,200
1/ 2 geth1/2       down  Access          1 (VLAN0001)
1/ 3 geth1/3       down  Access          1 (VLAN0001)
1/ 4 geth1/4       down  Access          1 (VLAN0001)
1/ 5 geth1/5       down  Access          1 (VLAN0001)
1/ 6 geth1/6       down  Access          1 (VLAN0001)
1/ 7 geth1/7       down  Access          1 (VLAN0001)
1/ 8 geth1/8       down  Access          1 (VLAN0001)
1/ 9 geth1/9       down  Access          1 (VLAN0001)
1/11 geth1/11      up    Tunnel          100 (VLAN0100)
1/12 geth1/12      up    Tunnel          200 (VLAN0200)
1/10 geth1/10      down  Access          1 (VLAN0001)
1/13 geth1/13      down  Access          1 (VLAN0001)
1/14 geth1/14      down  Access          1 (VLAN0001)
1/15 geth1/15      down  Access          1 (VLAN0001)
1/16 geth1/16      down  Access          1 (VLAN0001)
1/17 geth1/17      down  Access          1 (VLAN0001)
1/18 geth1/18      down  Access          1 (VLAN0001)
1/19 geth1/19      down  Access          1 (VLAN0001)
1/20 geth1/20      down  Access          1 (VLAN0001)
1/21 geth1/21      down  Access          1 (VLAN0001)
1/22 geth1/22      down  Access          1 (VLAN0001)
1/23 geth1/23      down  Access          1 (VLAN0001)
1/24 geth1/24      down  Access          1 (VLAN0001)
AX6708S#
AX6708S#
AX6708S#
AX6708S# show vlan 100 detail
Date 2009/01/26 14:05:25 JST
VLAN counts:1      VLAN tunneling enabled
VLAN ID:100      Type:Port based      Status:Up
  Learning:On          Tag-Translation:
  BPDU Forwarding:    EAPOL Forwarding:
  Router Interface Name:VLAN0100
  IP Address:
  Source MAC address: 0012.e2e0.1400(System)
  Description:VLAN0100
  Spanning Tree:
  AXRP RING ID:        AXRP VLAN group:
  GSRP ID:            GSRP VLAN group:    L3:
  IGMP snooping:      MLD snooping:
  Flow mode:
  Port Information
    1/1      Down -          Tagged
    1/11     Up    Forwarding      Untagged
AX6708S#

```

1.2 Tag conversion

This section describes a configuration example of a tag conversion that re-assigns a VLAN tag received within a switch to another VLAN.

[Configuration figure]

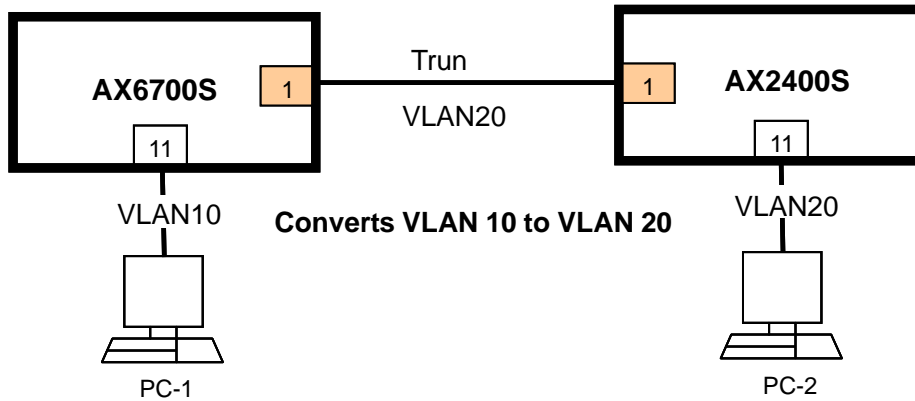

[Explanation of the configuration figure]

The tag that goes out from the switch AX2400S as VLAN 20 will be converted to VLAN 10 on the switch AX6700S.

Configuration key point

- Configure the conversion on port 1/1 of the switch AX6700S.

[Configuration examples]

● AX6700S

```
1.(config)# vlan 10,20
   (config-vlan)# exit

2.(config)# interface gigabitethernet 1/1
3.(config-if)# switchport mode trunk
4.(config-if)# switchport trunk allowed vlan 10
5.(config-if)# switchport vlan mapping enable
6.(config-if)# switchport vlan mapping 20 10
   (config-if)# exit

7.(config)# interface gigabitethernet 1/11
   (config-if)# switchport mode access
   (config-if)# switchport access vlan 10
   (config-if)# exit
```

1. Creates VLAN 10 and VLAN 20 before and after the conversion
2. Sets port 1/1 as the port where tag conversion is performed
3. Places the switch port in trunking mode
4. Assigns VLAN 10, which is to be used within the switch, to port 1/1
5. Enables tag conversion
6. Sets the tag that comes in from the outside via VLAN 20 to convert to VLAN 10
7. Sets port 1/11 as the access port for checking

● AX2400S

```
1.(config)# vlan 20
   (config-vlan)# exit

2.(config)# interface gigabitethernet 0/1
   (config-if)# media-type rj45
   (config-if)# switchport mode trunk
   (config-if)# switchport trunk allowed vlan 20
   (config-if)# exit

3.(config)# interface gigabitethernet 0/11
   (config-if)# switchport mode access
   (config-if)# switchport access vlan 20
   (config-if)# exit
```

1. Creates VLAN 20
2. Places port 0/1 in trunking mode and sets VLAN 20 to the port
3. Sets port 0/11 as the access port for checking

[Operation example]

● VLAN status

```

AX6708S# show port vlan
Date 2009/01/26 14:27:57 JST
Port Counts: 24
Port Name           Status Type      VLAN
1/ 1 geth1/1        up    Trunk      10 (VLAN0010)
1/ 2 geth1/2        down  Access     1 (VLAN0001)
1/ 3 geth1/3        down  Access     1 (VLAN0001)
1/ 4 geth1/4        down  Access     1 (VLAN0001)
1/ 5 geth1/5        down  Access     1 (VLAN0001)
1/ 6 geth1/6        down  Access     1 (VLAN0001)
1/ 7 geth1/7        down  Access     1 (VLAN0001)
1/ 8 geth1/8        down  Access     1 (VLAN0001)
1/ 9 geth1/9        down  Access     1 (VLAN0001)
1/10 geth1/10       down  Access     1 (VLAN0001)
1/11 geth1/11       down  Access     10 (VLAN0010)
1/12 geth1/12       down  Access     1 (VLAN0001)
1/13 geth1/13       down  Access     1 (VLAN0001)
1/14 geth1/14       down  Access     1 (VLAN0001)
1/15 geth1/15       down  Access     1 (VLAN0001)
1/16 geth1/16       down  Access     1 (VLAN0001)
1/17 geth1/17       down  Access     1 (VLAN0001)
1/18 geth1/18       down  Access     1 (VLAN0001)
1/19 geth1/19       down  Access     1 (VLAN0001)
1/20 geth1/20       down  Access     1 (VLAN0001)
1/21 geth1/21       down  Access     1 (VLAN0001)
1/22 geth1/22       down  Access     1 (VLAN0001)
1/23 geth1/23       down  Access     1 (VLAN0001)
1/24 geth1/24       down  Access     1 (VLAN0001)
AX6708S#
AX6708S#
AX6708S# show vlan 10 detail
Date 2009/01/26 14:28:06 JST
VLAN counts:1
VLAN ID:10      Type:Port based      Status:Up
  Learning:On      Tag-Translation:On
  BPDU Forwarding:  EAPOL Forwarding:
  Router Interface Name:VLAN0010
  IP Address:192.168.1.1/24
  Source MAC address: 0012.e2e0.1400(System)
  Description:VLAN0010
  Spanning Tree:PVST+(802.1D)
  AXRP RING ID:      AXRP VLAN group:
  GSRP ID:          GSRP VLAN group:  L3:
  IGMP snooping:    MLD snooping:
  Flow mode:
  Port Information
    1/1      Up    Forwarding    Tagged    Tag-Translation:20
    1/11     Down -          Untagged
AX6708S#

```

1.3 PVST+

Among the spanning-tree functionalities, this section describes a configuration example using PVST+, which builds a tree for each VLAN.

[Configuration figure]

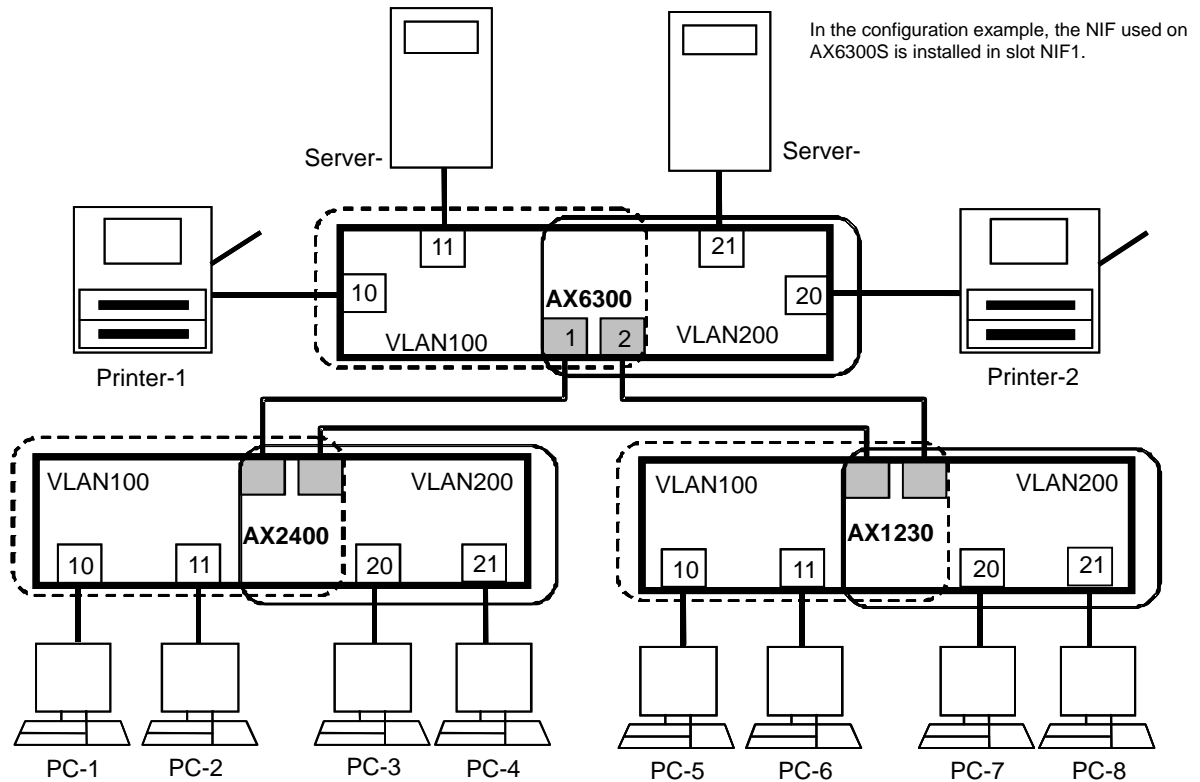

[Explanation of the configuration figure]

The above example shows a closed-loop configuration that configures the switches AX6300, AX2400, and AX1230 using PVST+.

Though not described in the figure, the configuration example specifies the switch AX6300 as the root bridge.

Since the three switches are made redundant as in the example, even if a failure occurs to the connection between the switches AX6300 and AX2400, the switches AX6300 and AX1230, or the switches AX2400 and AX1230, the route is switched over to another connection to restart communication.

Also, with the exception of the switch AX6300, either port 1 and port 2 of the switch AX2400, and port 1 and port 2 of the switch AX1230, serve as blocking ports so even a closed-loop configuration like this does not cause endless circulation of frames over the loop to disrupt communication.

Configuration key points

- Use PVST+ as the spanning tree.
- Configure two VLANs (VLAN 100 and VLAN 200) on each of the Switches (the switch AX6300, AX2400, and the switch AX1230).
- Set the ports between the three switches as trunk ports.
- Enable PortFast on the ports that do not perform spanning-tree functionality.
- To specify the switch AX6300 as the root bridge, set a value (higher bridge priority) to the switch AX6300 lower than the switches AX2400 and AX1230.

If you use an AX1240S series switch instead of an AX1230S series switch to build a configuration, replace the switch AX1230 in the configuration figure and in the explanation of the configuration figure with an AX1240S series switch.

[Configuration examples]

● AX6300S

```
1.(config)# vlan 100,200
   (config-vlan)# exit

2.(config)# spanning-tree mode pvst
3.(config)# spanning-tree vlan 100 priority 4096
   (config)# spanning-tree vlan 200 priority 4096
4.(config)# spanning-tree portfast default

5.(config)# interface range gigabitethernet 1/1-2
   (config-if-range)# switchport mode trunk
   (config-if-range)# switchport trunk allowed vlan 100,200
6.(config-if-range)# spanning-tree portfast disable
   (config-if-range)# exit

7.(config)# interface range gigabitethernet 1/10-11
   (config-if-range)# switchport mode access
   (config-if-range)# switchport access vlan 100
   (config-if-range)# exit

8.(config)# interface range gigabitethernet 1/20-21
   (config-if-range)# switchport mode access
   (config-if-range)# switchport access vlan 200
   (config-if-range)# exit
```

1. Creates VLAN 100 and VLAN 200
2. Sets the operation mode of the spanning tree to PVST+
3. Sets the bridge priority of PVST+ for VLAN 100 and VLAN 200 to 4096
4. Enables PortFast for all the ports of the switch AX6300S
5. Sets VLAN 100 and VLAN 200 to ports 1/1 and 1/2 as trunk ports, respectively
6. Disables PortFast on ports 1/1 and 1/2
7. Sets VLAN 100 to ports 1/10 and 1/11 as access ports
8. Sets VLAN 200 to ports 1/20 and 1/21 as access ports

● AX2400S

```
1.(config)# vlan 100,200
   (config-vlan)# exit

2.(config)# spanning-tree mode pvst
3.(config)# spanning-tree vlan 100 priority 8192
   (config)# spanning-tree vlan 200 priority 8192
4.(config)# spanning-tree portfast default

5.(config)# interface range gigabitethernet 0/1-2
   (config-if-range)# switchport mode trunk
   (config-if-range)# switchport trunk allowed vlan 100,200
6.(config-if-range)# spanning-tree portfast disable
   (config-if-range)# media-type rj45
   (config-if-range)# exit

7.(config)# interface range gigabitethernet 0/10-11
   (config-if-range)# switchport mode access
   (config-if-range)# switchport access vlan 100
   (config-if-range)# exit

8.(config)# interface range gigabitethernet 0/20-21
   (config-if-range)# switchport mode access
   (config-if-range)# switchport access vlan 200
   (config-if-range)# exit
```

1. Creates VLAN 100 and VLAN 200
2. Sets the operation mode of the spanning tree to PVST+
3. Sets the bridge priority of PVST+ for VLAN 100 and VLAN 200 to 8192
4. Enables PortFast for all the ports of the switch AX2400S
5. Sets VLAN 100 and VLAN 200 to ports 0/1 and 0/2 as trunk ports, respectively
6. Disables PortFast on ports 0/1 and 0/2
7. Sets VLAN 100 to ports 0/10 and 0/11 as access ports
8. Sets VLAN 200 to ports 0/20 and 0/21 as access ports

● AX1230S

```
1.(config)# vlan 100,200
   (config-vlan)# exit

2.(config)# spanning-tree mode pvst
3.(config)# spanning-tree vlan 100 priority 8192
   (config)# spanning-tree vlan 200 priority 8192
4.(config)# spanning-tree portfast default

5.(config)# interface range fastethernet 0/1-2
   (config-if-range)# switchport mode trunk
   (config-if-range)# switchport trunk allowed vlan 100,200
6.(config-if-range)# spanning-tree portfast disable
   (config-if-range)# exit

7.(config)# interface range fastethernet 0/10-11
   (config-if-range)# switchport mode access
   (config-if-range)# switchport access vlan 100
   (config-if-range)# exit

8.(config)# interface range fastethernet 0/20-21
   (config-if-range)# switchport mode access
   (config-if-range)# switchport access vlan 200
   (config-if-range)# exit
```

1. Creates VLAN 100 and VLAN 200
2. Sets the operation mode of the spanning tree to PVST+
3. Sets the bridge priority of PVST+ for VLAN 100 and VLAN 200 to 8192
4. Enables PortFast for all the ports of the switch AX1230S
5. Sets VLAN 100 and VLAN 200 to ports 0/1 and 0/2 as trunk ports, respectively
6. Disables PortFast on ports 0/1 and 0/2
7. Sets VLAN 100 to ports 0/10 and 0/11 as access ports
8. Sets VLAN 200 to ports 0/20 and 0/21 as access ports

● Differences in the configuration content between AX1230S series switches and AX1240S series switches

In the configuration content in this section, there is no difference between AX1230S series switches and AX1240S series switches.

1.4 Load balancing using PVST+

This section describes a configuration example that performs load balancing using PVST+, which builds a tree for each VLAN.

[Configuration figure]

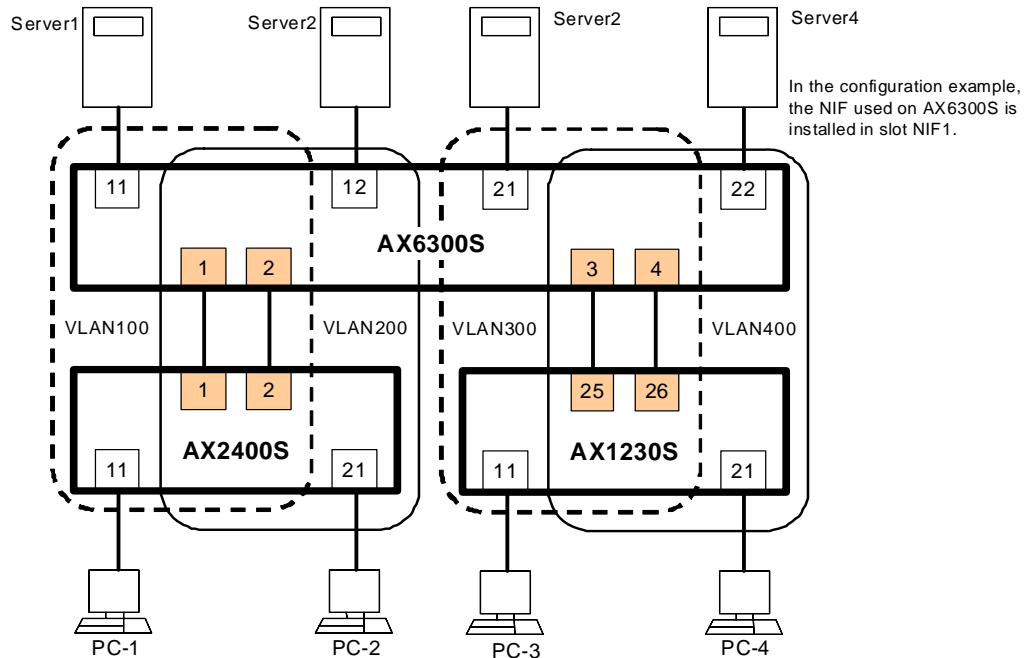

[Explanation of the configuration figure]

The configurations of the switch AX6300S and the switch AX2400S, and the switch AX6300S and the switch AX1230S are closed-loop configurations that use PVST+.

By adjusting the path cost of each VLAN, the communication load can be shared during normal operation as follows:

- Communication between PC-1 and Server 1: Between port 1 of the switch AX2400S and port 1 of the switch AX6300S
- Communication between PC-2 and Server 2: Between port 2 of the switch AX2400S and port 2 of the switch AX6300S
- Communication between PC-3 and Server 3: Between port 25 of the switch AX2400S and port 3 of the switch AX6300S
- Communication between PC-3 and Server 3: Between port 26 of the switch AX2400S and port 4 of the switch AX6300S

Two ports configured as trunk ports are connected between the switches. This will ensure that, if one of the ports fails, the load can be concentrated on the other port to continue the communication.

Though not described in the figure, the configuration example specifies the switch AX6300S as the root bridge.

Configuration key points

- Use PVST+ as the spanning tree.
- Set the following VLANs to the switches (AX6300S, AX2400S, and AX1230S).
AX6300S: VLAN 100, 200, 300, and 400; AX2400S: VLAN 100 and 200; AX1230S: VLAN 300 and 400
- Set the ports between the switches (between the switch AX6300S and the switch AX2400S and between the switch AX6300S and the switch AX1230S) as trunk ports.
- Enables PortFast on the ports that do not perform spanning-tree functionality.
- To specify the switch AX6300S as the root bridge, set a lower value (higher bridge priority) to the switch AX6300S than to the switch AX2400S and the switch AX1230S.
- To perform load balancing during normal operation, configure the path cost of the VLANs of the switches as follows:
 - AX6300S Port 1: Path cost value of VLAN 100 < path cost value of VLAN 200
 - Port 2: Path cost value of VLAN 200 < path cost value of VLAN 100
 - Port 3: Path cost value of VLAN 300 < path cost value of VLAN 400
 - Port 4: Path cost value of VLAN 400 < path cost value of VLAN 300
 - AX2400S Port 1: Path cost value of VLAN 100 < path cost value of VLAN 200
 - Port 2: Path cost value of VLAN 200 < path cost value of VLAN 100
 - AX1230S Port 25: Path cost value of VLAN 300 < path cost value of VLAN 400
 - Port 26: Path cost value of VLAN 400 < path cost value of VLAN 300

If you use an AX1240S series switch instead of an AX1230S series switch to build a configuration, replace the switch AX1230S in the configuration figure and in the explanation of the configuration figure with an AX1240S series switch.

[Configuration examples]

● AX6300S

```
1.(config)# vlan 100,200,300,400
   (config-vlan)# exit

2.(config)# spanning-tree mode pvst
3.(config)# spanning-tree vlan 100 priority 4096
   (config)# spanning-tree vlan 200 priority 4096
   (config)# spanning-tree vlan 300 priority 4096
   (config)# spanning-tree vlan 400 priority 4096
4.(config)# spanning-tree portfast default

5.(config)# interface range gigabitethernet 1/1-2
   (config-if-range)# switchport mode trunk
   (config-if-range)# switchport trunk allowed vlan 100,200
6.(config-if-range)# spanning-tree portfast disable
   (config-if-range)# exit

7.(config)# interface gigabitethernet 1/1
   (config-if)# spanning-tree vlan 100 cost 2
   (config-if)# spanning-tree vlan 200 cost 4
   (config-if)# exit

8.(config)# interface gigabitethernet 1/2
   (config-if)# spanning-tree vlan 100 cost 4
   (config-if)# spanning-tree vlan 200 cost 2
   (config-if)# exit

9.(config)# interface range gigabitethernet 1/3-4
   (config-if-range)# switchport mode trunk
   (config-if-range)# switchport trunk allowed vlan 300,400
   (config-if-range)# spanning-tree portfast disable
   (config-if-range)# exit

10.(config)# interface gigabitethernet 1/3
   (config-if)# spanning-tree vlan 300 cost 2
   (config-if)# spanning-tree vlan 400 cost 4
   (config-if)# exit

11.(config)# interface gigabitethernet 1/4
   (config-if)# spanning-tree vlan 300 cost 4
   (config-if)# spanning-tree vlan 400 cost 2
   (config-if)# exit

12.(config)# interface gigabitethernet 1/11
   (config-if)# switchport mode access
   (config-if)# switchport access vlan 100
   (config-if)# exit

13.(config)# interface gigabitethernet 1/12
   (config-if)# switchport mode access
   (config-if)# switchport access vlan 200
   (config-if)# exit

14.(config)# interface gigabitethernet 1/21
   (config-if)# switchport mode access
   (config-if)# switchport access vlan 300
   (config-if)# exit

15.(config)# interface gigabitethernet 1/22
   (config-if)# switchport mode access
   (config-if)# switchport access vlan 400
   (config-if)# exit
```

1. Creates VLAN 100, VLAN 200, VLAN 300, and VLAN 400
2. Sets the operation mode of the spanning tree to PVST+
3. Sets the bridge priority of PVST+ for VLAN 100, VLAN 200, VLAN 300, and VLAN 400 to 4096
4. Enables PortFast on all the ports of AX6300S
5. Sets VLAN 100 and VLAN 200 to ports 1/1 and 1/2 as trunk ports, respectively
6. Disables PortFast on ports 1/1 and 1/2
7. On port 1/1, sets the path cost of VLAN 100 to 2 and the path cost of VLAN 200 to 4
8. On port 1/2, sets the path cost of VLAN 100 to 4 and the path cost of VLAN 200 to 2
9. Sets trunk ports of VLAN 300 and VLAN 400 to ports 1/3 and 1/4, respectively, and disables the PortFast function
10. On port 1/3, sets the path cost of VLAN 300 to 2 and the path cost of VLAN 400 to 4
11. On port 1/4, sets the path cost of VLAN 300 to 4 and the path cost of VLAN 400 to 2
12. Sets VLAN 100 to port 1/11 as an access port
13. Sets VLAN 200 to port 1/12 as an access port
14. Sets VLAN 300 to port 1/21 as an access port
15. Sets VLAN 400 to port 1/22 as an access port

● AX2400S

```
1.(config)# vlan 100,200
   (config-vlan)# exit

2.(config)# spanning-tree mode pvst
3.(config)# spanning-tree vlan 100 priority 8192
   (config)# spanning-tree vlan 200 priority 8192
4.(config)# spanning-tree portfast default

5.(config)# interface range gigabitethernet 0/1-2
   (config-if-range)# switchport mode trunk
   (config-if-range)# switchport trunk allowed vlan 100,200
   (config-if-range)# media-type rj45
6.(config-if-range)# spanning-tree portfast disable
   (config-if-range)# exit

7.(config)# interface gigabitethernet 0/1
   (config-if)# spanning-tree vlan 100 cost 2
   (config-if)# spanning-tree vlan 200 cost 4
   (config-if)# exit

8.(config)# interface gigabitethernet 0/2
   (config-if)# spanning-tree vlan 100 cost 4
   (config-if)# spanning-tree vlan 200 cost 2
   (config-if)# exit

9.(config)# interface gigabitethernet 0/11
   (config-if)# switchport mode access
   (config-if)# switchport access vlan 100
   (config-if)# exit

10.(config)# interface gigabitethernet 0/21
   (config-if)# switchport mode access
   (config-if)# switchport access vlan 200
   (config-if)# exit
```

1. Creates VLAN 100 and VLAN 200
2. Sets the operation mode of the spanning tree to PVST+
3. Sets the bridge priority of PVST+ for VLAN 100 and VLAN 200 to 8192
4. Enables PortFast on all the ports of the switch AX2400S
5. Sets VLAN 100 and VLAN 200 to ports 0/1 and 0/2 as trunk ports, respectively
6. Disables PortFast on ports 0/1 and 0/2
7. On port 0/1, sets the path cost of VLAN 100 to 2 and the path cost of VLAN 200 to 4
8. On port 0/2, sets the path cost of VLAN 100 to 4 and the path cost of VLAN 200 to 2
9. Sets VLAN 100 to port 0/11 as an access port
10. Sets VLAN 200 to port 0/21 as an access port

● AX1230S

```
1.(config)# vlan 300,400
   (config-vlan)# exit

2.(config)# spanning-tree mode pvst
3.(config)# spanning-tree vlan 300 priority 8192
   (config)# spanning-tree vlan 400 priority 8192
4.(config)# spanning-tree portfast default

5.(config)# interface range gigabitethernet 0/25-26
   (config-if-range)# switchport mode trunk
   (config-if-range)# switchport trunk allowed vlan 300,400
   (config-if-range)# media-type rj45
6.(config-if-range)# spanning-tree portfast disable
   (config-if-range)# exit

7.(config)# interface gigabitethernet 0/25
   (config-if)# spanning-tree vlan 300 cost 2
   (config-if)# spanning-tree vlan 400 cost 4
   (config-if)# exit

8.(config)# interface gigabitethernet 0/26
   (config-if)# spanning-tree vlan 300 cost 4
   (config-if)# spanning-tree vlan 400 cost 2
   (config-if)# exit

9.(config)# interface fastethernet 0/11
   (config-if)# switchport mode access
   (config-if)# switchport access vlan 300
   (config-if)# exit

10.(config)# interface fastethernet 0/21
   (config-if)# switchport mode access
   (config-if)# switchport access vlan 400
   (config-if)# exit
```

1. Creates VLAN 300 and VLAN 400
2. Sets the operation mode of the spanning tree to PVST+
3. Sets the bridge priority of PVST+ for VLAN 300 and VLAN 400 to 8192
4. Enables PortFast on all the ports of the switch AX1230S
5. Sets VLAN 300 and VLAN 400 to ports 0/25 and 0/26 as trunk ports, respectively
6. Disables PortFast on ports 0/25 and 0/26
7. On port 0/25, sets the path cost of VLAN 300 to 2 and the path cost of VLAN 400 to 4
8. On port 0/26, sets the path cost of VLAN 300 to 4 and the path cost of VLAN 400 to 2
9. Sets VLAN 300 to port 0/11 as an access port
10. Sets VLAN 400 to port 0/21 as an access port

● Differences in the configuration content between AX1230S series switches and AX1240S series switches

In the configuration content in this section, there is no difference between AX1230S series switches and AX1240S series switches.

[Operation command]

● AX6300S

[Shows spanning-tree information]

```

AX6304S# show spanning-tree vlan 100-400
Date 2008/12/10 09:53:33 JST
VLAN 100          PVST+ Spanning Tree:Enabled Mode:PVST+
  Bridge ID      Priority:4196          MAC Address:0012.e2a0.1800
  Bridge Status:Root
  Root Bridge ID Priority:4196          MAC Address:0012.e2a0.1800
  Root Cost:0
  Root Port:-
  Port Information
    1/1          Up      Status:Forwarding Role:Designated
    1/2          Up      Status:Forwarding Role:Designated
    1/11         Up      Status:Forwarding Role:Designated PortFast
VLAN 200          PVST+ Spanning Tree:Enabled Mode:PVST+
  Bridge ID      Priority:4296          MAC Address:0012.e2a0.1800
  Bridge Status:Root
  Root Bridge ID Priority:4296          MAC Address:0012.e2a0.1800
  Root Cost:0
  Root Port:-
  Port Information
    1/1          Up      Status:Forwarding Role:Designated
    1/2          Up      Status:Forwarding Role:Designated
    1/12         Up      Status:Forwarding Role:Designated PortFast
VLAN 300          PVST+ Spanning Tree:Enabled Mode:PVST+
  Bridge ID      Priority:4396          MAC Address:0012.e2a0.1800
  Bridge Status:Root
  Root Bridge ID Priority:4396          MAC Address:0012.e2a0.1800
  Root Cost:0
  Root Port:-
  Port Information
    1/3          Up      Status:Forwarding Role:Designated
    1/4          Up      Status:Forwarding Role:Designated
    1/21         Up      Status:Forwarding Role:Designated PortFast
VLAN 400          PVST+ Spanning Tree:Enabled Mode:PVST+
  Bridge ID      Priority:4496          MAC Address:0012.e2a0.1800
  Bridge Status:Root
  Root Bridge ID Priority:4496          MAC Address:0012.e2a0.1800
  Root Cost:0
  Root Port:-
  Port Information
    1/3          Up      Status:Forwarding Role:Designated
    1/4          Up      Status:Forwarding Role:Designated
    1/22         Up      Status:Forwarding Role:Designated PortFast

```

● AX2400S

[Shows spanning-tree information]

```

AX2430S# show spanning-tree vlan 100-200
Date 2008/12/10 09:56:19 JST
VLAN 100 PVST+ Spanning Tree:Enabled Mode:PVST+
  Bridge ID Priority:8292 MAC Address:0012.e208.21db
  Bridge Status:Designated
  Root Bridge ID Priority:4196 MAC Address:0012.e2a0.1800
  Root Cost:2
  Root Port:0/1
  Port Information
    0/1 Up Status:Forwarding Role:Root
    0/2 Up Status:Blocking Role:Alternate
    0/11 Up Status:Forwarding Role:Designated PortFast
VLAN 200 PVST+ Spanning Tree:Enabled Mode:PVST+
  Bridge ID Priority:8392 MAC Address:0012.e208.21db
  Bridge Status:Designated
  Root Bridge ID Priority:4296 MAC Address:0012.e2a0.1800
  Root Cost:2
  Root Port:0/2
  Port Information
    0/1 Up Status:Blocking Role:Alternate
    0/2 Up Status:Forwarding Role:Root
    0/21 Up Status:Forwarding Role:Designated PortFast

```

● AX1230S

[Shows spanning-tree information]

```

AX1230S# show spanning-tree vlan 300-400
Date 2008/12/10 09:56:14 JST
VLAN 300 PVST+ Spanning Tree:Enabled Mode:PVST+
  Bridge ID Priority: 8492 MAC Address: 00ee.f013.0001
  Bridge Status: Designated
  Root Bridge ID Priority: 4396 MAC Address: 0012.e2a0.1800
  Root Cost: 2
  Root Port: 0/25
  Port Information
    0/11 Up Status:Forwarding Role:Designated PortFast
    0/25 Up Status:Forwarding Role:Root -
    0/26 Up Status:Blocking Role:Alternate -
VLAN 400 PVST+ Spanning Tree:Enabled Mode:PVST+
  Bridge ID Priority: 8592 MAC Address: 00ee.f013.0001
  Bridge Status: Designated
  Root Bridge ID Priority: 4496 MAC Address: 0012.e2a0.1800
  Root Cost: 2
  Root Port: 0/26
  Port Information
    0/21 Up Status:Forwarding Role:Designated PortFast
    0/25 Up Status:Blocking Role:Alternate -
    0/26 Up Status:Forwarding Role:Root -

```

● Differences in the command execution results between AX1230S series switches and AX1240S series switches

There is no difference in the command execution result of show spanning-tree between AX1230S series switches and AX1240S series switches.

1.5 Root guard functionality of spanning trees

This section describes a configuration example of root guard, an extended functionality of the spanning tree.

[Configuration figure]

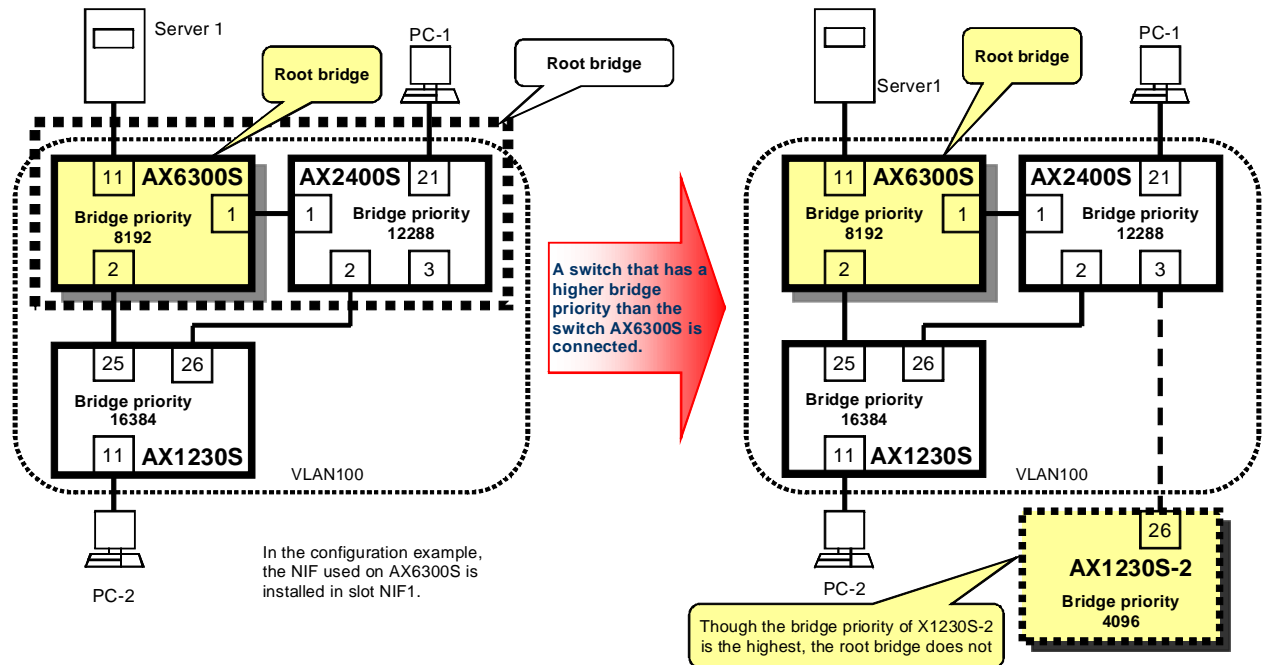

[Explanation of the configuration figure]

This is a closed-loop configuration that configures the switches AX6300S, AX2400S, and AX1230S using the spanning tree (PVST+).

As shown in the right figure, if you add a switch that has a higher bridge priority (the switch AX1230S-2) than the existing root bridge (the switch AX6300S), an unintended topology might occur to stop the communication temporarily. In addition, the root bridge might transfer to the added switch, not to the initially planned root bridge candidate.

Enable root guard functionality for the ports of the existing switches that are not connected to the root bridge candidate (switches AX6300S, AX2400S, and AX1230S).

This will prevent unintended topologies and the transfer of the root bridge to another switch than the planned one, if a switch that has a higher bridge priority than the existing root bridge is accidentally connected.

Configuration key points

- Use PVST+ as the spanning tree.
- Set VLAN 100 to each switch.
- Determine the root bridge.
 - Set the bridge priorities of the switches so that the root bridge will be the switch AX6300S and so that the next candidate will be the switch AX2400S.
- Set root guard functionality for the ports that are not connected to the root bridge candidate.
 - AX6300S: Set root guard functionality for all the ports used by VLAN 100.
 - AX2400S: Set root guard functionality for the ports used by VLAN 100 except port 1, which is connected to AX6300S.
 - AX1230S: Set root guard functionality for the ports used by VLAN 100 except port 25, which is connected to the switch AX6300S, and port 26, which is connected to the switch AX2400S.

If you use a AX1240S series switch instead of a AX1230S series switch to build a configuration, replace switch AX1230S in the configuration figure and in the explanation of the configuration figure with an AX1240S series switch.

[Configuration examples]

● AX6300S

```
1.(config)# vlan 100
   (config-vlan)# exit

2.(config)# spanning-tree mode pvst
3.(config)# spanning-tree vlan 100 priority 8192

4.(config)# interface range gigabitethernet 1/1-2
   (config-if-range)# switchport mode access
   (config-if-range)# switchport access vlan 100
5.(config-if-range)# spanning-tree guard root
   (config-if-range)# exit

6.(config)# interface gigabitethernet 1/11
   (config-if)# switchport mode access
   (config-if)# switchport access vlan 100
   (config-if)# spanning-tree guard root
   (config-if)# exit
```

1. Creates VLAN 100
2. Sets the operation mode of the spanning tree to PVST+
3. Sets the bridge priority of PVST+ for VLAN 100 to 8192
4. Sets VLAN 100 to port 1/1 and port 1/2 as an access port
5. Sets root guard functionality for ports 1/1 and 1/2
6. Sets root guard functionality for port 1/11 and sets VLAN 100 to port 1/11 as an access port

● AX2400S

```
1.(config)# vlan 100
   (config-vlan)# exit

2.(config)# spanning-tree mode pvst
3.(config)# spanning-tree vlan 100 priority 12288

4.(config)# interface range gigabitethernet 0/1-3
   (config-if-range)# switchport mode access
   (config-if-range)# switchport access vlan 100
   (config-if-range)# media-type rj45
5.(config-if-range)# spanning-tree guard root
   (config-if-range)# exit

6.(config)# interface gigabitethernet 0/1
   (config-if)# spanning-tree guard none
   (config-if)# exit

7.(config)# interface gigabitethernet 0/21
   (config-if)# switchport mode access
   (config-if)# switchport access vlan 100
   (config-if)# spanning-tree guard root
   (config-if)# exit
```

1. Creates VLAN 100 as a port VLAN
2. Sets the operation mode of the spanning tree to PVST+
3. Sets the bridge priority of PVST+ for VLAN 100 to 12288
4. Sets ports 0/1 through 0/3 as access ports of VLAN 100
5. Enables root guard functionality for ports 0/1 through 0/3
6. Disables root guard functionality for port 0/1
7. Sets root guard functionality for port 0/21 and sets VLAN 100 to port 0/21 as an access port

● AX1230S

```
1.(config)# vlan 100
   (config-vlan)# exit

2.(config)# spanning-tree mode pvst
3.(config)# spanning-tree vlan 100 priority 16384

4.(config)# interface range gigabitethernet 0/25-26
   (config-if-range)# switchport mode access
   (config-if-range)# switchport access vlan 100
   (config-if-range)# media-type rj45
   (config-if-range)# exit

5.(config)# interface fastethernet 0/11
   (config-if)# switchport mode access
   (config-if)# switchport access vlan 100
   (config-if)# spanning-tree guard root
   (config-if)# exit
```

1. Creates VLAN 100
2. Sets the operation mode of the spanning tree to PVST+
3. Sets the bridge priority of PVST+ for VLAN 100 to 16384
4. Sets VLAN 100 to port 0/25 and port 0/26 as an access port
5. Sets root guard functionality for port 0/11 and sets VLAN 100 to port 0/11 as an access port

● Differences in the configuration content between AX1230S series switches and AX1240 series switches

In the configuration content in this section, there is no difference between AX1230S series switches and AX1240S series switches.

[Operation command]

● AX6300S

[Shows spanning-tree information]

```

AX6304S# show spanning-tree vlan 100
Date 2008/12/10 14:13:27 JST
VLAN 100          PVST+ Spanning Tree:Enabled Mode:PVST+
  Bridge ID      Priority:8292          MAC Address:0012.e2a0.1800
  Bridge Status:Root
Root Bridge ID   Priority:8292          MAC Address:0012.e2a0.1800
Root Cost:0
Root Port:-
Port Information
  1/1           Up      Status:Forwarding  Role:Designated RootGuard
  1/2           Up      Status:Forwarding  Role:Designated RootGuard
  1/11          Up      Status:Forwarding  Role:Designated RootGuard
    
```

● AX2400S

[Shows spanning-tree information]

```

AX2430S# show spanning-tree vlan 100
Date 2008/12/18 11:35:03 JST
VLAN 100          PVST+ Spanning Tree:Enabled Mode:PVST+
  Bridge ID      Priority:12388          MAC Address:0012.e208.21db
  Bridge Status:Designated
Root Bridge ID   Priority:8292          MAC Address:0012.e2a0.1800
Root Cost:4
Root Port:0/1
Port Information
  0/1           Up      Status:Forwarding  Role:Root
  0/2           Up      Status:Forwarding  Role:Designated RootGuard
  0/3           Down    Status:Disabled    Role:-              RootGuard
  0/21          Up      Status:Forwarding  Role:Designated RootGuard
    
```

· Spanning-tree information, when a switch that has a higher bridge priority than the existing root bridge (the switch AX6300S) is connected to port 0/3

```

AX2430S# show spanning-tree vlan 100
Date 2008/12/10 14:13:37 JST
VLAN 100          PVST+ Spanning Tree:Enabled Mode:PVST+
  Bridge ID      Priority:12388          MAC Address:0012.e208.21db
  Bridge Status:Designated
Root Bridge ID   Priority:8292          MAC Address:0012.e2a0.1800
Root Cost:4
Root Port:0/1
Port Information
  0/1           Up      Status:Forwarding  Role:Root
  0/2           Up      Status:Forwarding  Role:Designated RootGuard
  0/3           Up      Status:Blocking    Role:Designated RootGuard
  0/21          Up      Status:Forwarding  Role:Designated RootGuard
    
```

● AX1230S

[Shows spanning-tree information]

```
AX1230S# show spanning-tree vlan 100

Date 2008/12/10 14:14:45 JST
VLAN 100 PVST+ Spanning Tree:Enabled Mode:PVST+
  Bridge ID      Priority: 16484      MAC Address: 00ee.f013.0001
  Bridge Status: Designated
  Root Bridge ID Priority: 8292      MAC Address: 0012.e2a0.1800
  Root Cost: 4
  Root Port: 0/25
Port Information
  0/11      Up      Status:Forwarding  Role:Designated  RootGuard
  0/25      Up      Status:Forwarding  Role:Root        -
  0/26      Up      Status:Blocking    Role:Alternate   -
```

● Differences in the command execution result between AX1230S series switches and AX1240S series switches

There is no difference in the command execution result of show spanning-tree between AX1230S series switches and AX1240S series switches.

1.6 IGMP snooping

This section describes a configuration example of IGMP snooping functionality.

[Configuration figure]

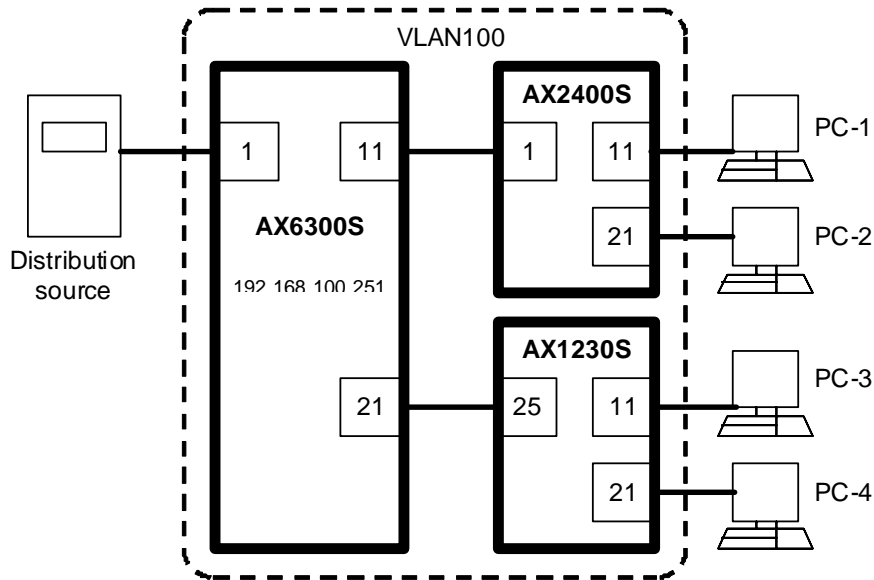

In the configuration example, the NIF used on AX6300S is installed in slot NIF1.

[Explanation of the configuration figure]

This is a single-VLAN IGMP snooping configuration that does not use multicast routers on switches AX6300S, AX2400S, and AX1230S.

Due to the absence of multicast routers, IGMP query messages are sent to PCs 1 through 4 using the IGMP querier functionality of the switch AX6300S by proxy.

Note that the AX1230S series switches do not support IGMPv3. Therefore, use IGMPv1/v2 hosts instead.

Configuration key points

- Add VLAN 100 to each switch and enable IGMP snooping for VLAN 100.
- Set the following items related to IGMP snooping on each switch.
 - AX6300S: Assign an IP address and set the IGMP querier to VLAN 100.
 - AX2400S: Set the multicast router port to the port that is connected to switch AX6300S. (Note that the configuration of the multicast router port must be performed only after setting the target port to VLAN100.)
 - AX1230S: Configure system function resources for IGMP snooping in advance. Set the port that is connected to switch AX6300S as a multicast router port.

If you use an AX1240S series switch instead of an AX1230S series switch to build a configuration, replace the switch AX1230S in the configuration figure and in the explanation of the configuration figure with an AX1240S series switch.

[Configuration examples]

● AX6300S

```
1.(config)# vlan 100
   (config-vlan)# exit

2.(config)# interface vlan 100
   (config-if)# ip address 192.168.100.251 255.255.255.0
3.(config-if)# ip igmp snooping
4.(config-if)# ip igmp snooping querier
   (config-if)# exit

5.(config)# interface gigabitethernet 1/1
   (config-if)# switchport mode access
   (config-if)# switchport access vlan 100
   (config-if)# exit

6.(config)# interface gigabitethernet 1/11
   (config-if)# switchport mode access
   (config-if)# switchport access vlan 100
   (config-if)# exit

7.(config)# interface gigabitethernet 1/21
   (config-if)# switchport mode access
   (config-if)# switchport access vlan 100
   (config-if)# exit
```

1. Creates VLAN 100
2. Assigns an IP address (192.168.100.251) and a subnet mask (24-bit mask) to VLAN 100
3. Enables IGMP snooping functionality for VLAN 100
4. Enables IGMP querier functionality for the VLAN 100 to which IGMP snooping is enabled
5. Sets VLAN 100 to port 1/1 as an access port
6. Sets VLAN 100 to port 1/11 as an access port
7. Sets VLAN 100 to port 1/21 as an access port

● AX2400S

```
1.(config)# vlan 100
   (config-vlan)# exit

2.(config)# interface gigabitethernet 0/1
   (config-if)# switchport mode access
   (config-if)# switchport access vlan 100
   (config-if)# media-type rj45
   (config-if)# exit

3.(config)# interface vlan 100
   (config-if)# ip igmp snooping
4.(config-if)# ip igmp snooping mrouter interface gigabitethernet 0/1
   (config-if)# exit

5.(config)# interface range gigabitethernet 0/11-21
   (config-if-range)# switchport mode access
   (config-if-range)# switchport access vlan 100
   (config-if-range)# exit
```

1. Creates VLAN 100
2. Sets VLAN 100 to port 0/1 as an access port
3. Enables IGMP snooping functionality for VLAN 100
4. Specifies port 0/1 as a multicast router port
5. Sets VLAN 100 to ports 0/11 through 0/21 as access ports

[Notes]

Before configuring a multicast router port on AX2400S series switches, make sure the port in question belongs to the VLAN for which IGMP snooping functionality is to be enabled.

In addition, before configuring a multicast router port, you need to enable IGMP snooping functionality for the VLAN in question. For details, see *14. IGMP snooping* in the *AX2400S Software Manual Configuration Command Reference*.

● AX1230S

```
1.(config)# vlan 100
   (config-vlan)# exit

2.(config)# interface gigabitethernet 0/25
   (config-if)# switchport mode access
   (config-if)# switchport access vlan 100
   (config-if)# media-type rj45
   (config-if)# exit

3.(config)# interface vlan 100
   (config-if)# ip igmp snooping
4.(config-if)# ip igmp snooping mrouter interface gigabitethernet 0/25
   (config-if)# exit

5.(config)# interface range fastethernet 0/11-21
   (config-if-range)# switchport mode access
   (config-if-range)# switchport access vlan 100
   (config-if-range)# exit
```

1. Creates VLAN 100
2. Sets VLAN 100 to port 0/25 as an access port
3. Enables IGMP snooping functionality for VLAN 100
4. Specifies port 0/25 as a multicast router port
5. Sets VLAN 100 to ports 0/11 through 0/21 as access ports

[Notes]

In order to use IGMP snooping on AX1230S series switches, the setting of system function resource allocation needs be set to default or IGMP snooping.

For details, see 9.1.6 *Setting system function resource allocation* in the *AX1200S Software Manual Configuration Guide Vol.1*.

● Differences in the configuration content between AX1230S series switches and AX1240S series switches

In the configuration content in this section, there is no difference between AX1230S series switches and AX1240S series switches.

To use IGMP snooping on AX1240S series switches, if you have not configured system function resource allocation (system function), you do not have to configure it.

For details, see 9.1.6 *Functionality that uses system function resources* in the *AX1240S Software Manual Configuration Guide Vol.1*.

[Operation command]

● AX6300S

[Shows IGMP snooping information]

```
AX6304S# show igmp-snooping
Date 2008/12/11 17:10:43 JST
VLAN counts: 1
VLAN: 100
  IP address: 192.168.100.251      Querier: enable
  IGMP querying system: 192.168.100.251
  Querier version: V2
  IPv4 Multicast routing: Off
  Port(3): 1/1,1/11,1/21
  Mrouter-port:
  Group Counts: 1
```

● AX2400S

[Shows IGMP snooping information]

```
AX2430S# show igmp-snooping
Date 2008/12/11 17:11:52 JST
VLAN counts: 1
VLAN: 100
  IP address:      Querier: disable
  IGMP querying system: 192.168.100.251
  Querier version: V2
  Port(12): 0/1,0/11-21
  Mrouter-port: 0/1
  Group Counts: 1
```

● AX1230S

[Shows IGMP snooping information]

```
AX1230S# show igmp-snooping

Date 2008/12/11 17:13:06 JST
VLAN counts: 1
VLAN 100:
  IP Address:      Querier: disable
  IGMP querying system: 192.168.100.251
  Port (12): 0/11-21,0/25
  Mrouter-port: 0/25
  Group counts: 1
```

● Differences in the command execution result between AX1230S series switches and AX1240S series switches

There is no difference in the command execution result of show igmp-snooping between AX1230S series switches and AX1240S series switches.

1.7 QoS

Among the scheduling functions of QoS, this section describes the configuration examples of PQ and WRR.

[Configuration figure]

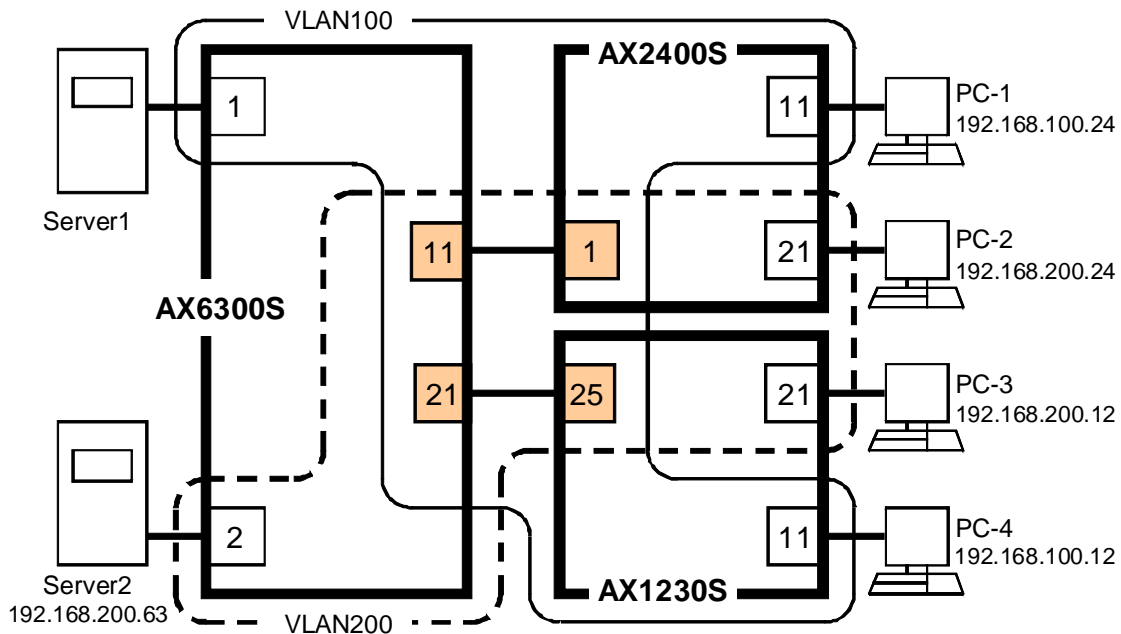

In the configuration example, the NIF used on the switch AX6300S is installed in slot NIF1.

[Explanation of the configuration figure]

This is a configuration figure that performs QoS scheduling (PQ and WRR) and sends frames to the PCs connected to the switch AX2400S and the switch AX1230S.

Set the scheduling mode of the ports as follows:

- AX2400S: PQ on port 11 and WRR on port 21
- AX1230S: PQ on port 11 and WRR on port 21

Configuration key points

- On the switch AX1230S, before configuring the flow detection, allocate system resources for QoS.
- On the switch AX2400S and the switch AX1230S, configure flow detection to set a higher priority to the frames relayed by the switch AX6300S.
Use Layer 2-2 as the flow detection mode.
Set the following priorities to the frames relayed by the switch AX6300S:
 - Frames from Server 1 and Server 2: CoS 7
 - Frames from PCs: CoS 3
- On the switch AX2400S and the switch AX1230S, enable scheduling functionality for the ports that are connected to PCs.

If you use an AX1240S series switch instead of an AX1230S series switch to build a configuration, replace switch AX1230S in the configuration figure and in the explanation of the configuration figure with an AX1240S series switch.

[Configuration examples]

● AX6300S

```
1.(config)# vlan 100,200
   (config-vlan)# exit

2.(config)# interface gigabitethernet 1/1
   (config-if)# switchport mode access
   (config-if)# switchport access vlan 100
   (config-if)# exit

3.(config)# interface gigabitethernet 1/2
   (config-if)# switchport mode access
   (config-if)# switchport access vlan 200
   (config-if)# exit

4.(config)# interface gigabitethernet 1/11
   (config-if)# switchport mode trunk
   (config-if)# switchport trunk allowed vlan 100,200
   (config-if)# exit

5.(config)# interface gigabitethernet 1/21
   (config-if)# switchport mode trunk
   (config-if)# switchport trunk allowed vlan 100,200
   (config-if)# exit
```

1. Creates VLAN 100 and VLAN 200
2. Sets VLAN 100 to port 1/1 as an access port
3. Sets VLAN 200 to port 1/2 as an access port
4. Sets VLAN 100 and VLAN 200 to port 1/11 as a trunk port
5. Sets VLAN 100 and VLAN 200 to port 1/21 as a trunk port

● AX2400S

```

1.(config)# vlan 100,200
   (config-vlan)# exit

2.(config)# flow detection mode layer2-2

3.(config)# ip qos-flow-list QOS-LIST
4 (config-ip-qos)# qos ip host 192.168.100.63 any action cos 7
5 (config-ip-qos)# qos ip host 192.168.200.63 any action cos 7
6 (config-ip-qos)# qos ip host 192.168.100.12 any action cos 3
7 (config-ip-qos)# qos ip host 192.168.200.12 any action cos 3
   (config-ip-qos)# exit

8.(config)# interface gigabitethernet 0/1
   (config-if)# switchport mode trunk
   (config-if)# switchport trunk allowed vlan 100,200
   (config-if)# media-type rj45
9.(config-if)# ip qos-flow-group QOS-LIST in
   (config-if)# exit

10.(config)# qos-queue-list QLIST-PQ pq

11.(config)# interface gigabitethernet 0/11
   (config-if)# switchport mode access
   (config-if)# switchport access vlan 100
12.(config-if)# qos-queue-group QLIST-PQ
   (config-if)# exit

13.(config)# qos-queue-list QLIST-WRR wr

14.(config)# interface gigabitethernet 0/21
   (config-if)# switchport mode access
   (config-if)# switchport access vlan 200
15.(config-if)# qos-queue-group QLIST-WRR
   (config-if)# exit

```

1. Creates VLAN 100 and VLAN 200
2. Enables the receiving-side flow detection mode Layer 2-2 (flow detection specialized for IPv4)
3. Creates an IPv4 QoS flow list (QOS-LIST)
4. Sets CoS value=7 in the QOS-LIST for the frames sent from the source IP address 192.168.100.63
5. Sets CoS value=7 in the QOS-LIST for the frames sent from the source IP address 192.168.200.63
6. Sets CoS value=3 in the QOS-LIST for the frames sent from the source IP address 192.168.100.12
7. Sets CoS value=3 in the QOS-LIST for the frames sent from the source IP address 192.168.200.12
8. Sets VLAN 100 and VLAN 200 to port 0/1 as a trunk port
9. Enables the QOS-LIST for port 0/1
10. Sets the scheduling mode of PQ to the QoS queue list information (QLIST-PQ)
11. Sets VLAN 100 to port 0/11 as an access port
12. Enables QoS queue list information (QLIST-PQ) for port 0/11
13. Sets the scheduling mode of weighted round-robin in the QoS queue list information (QLIST-WRR)
14. Sets port 0/21 as the access port of VLAN 200
15. Enables the QoS queue list information (QLIST-WRR) for port 0/21

● AX1230S

```
1.(config)# vlan 100,200
   (config-vlan)# exit

2.(config)# flow detection mode layer2-2

3.(config)# ip qos-flow-list extended QOS-LIST
4 (config-ip-qos)# qos protocol ip src 192.168.100.63 0.0.0.0
   dst 0.0.0.0 255.255.255.255 action cos 7
5 (config-ip-qos)# qos protocol ip src 192.168.200.63 0.0.0.0
   dst 0.0.0.0 255.255.255.255 action cos 7
6 (config-ip-qos)# qos protocol ip src 192.168.100.24 0.0.0.0
   dst 0.0.0.0 255.255.255.255 action cos 3
7 (config-ip-qos)# qos protocol ip src 192.168.200.24 0.0.0.0
   dst 0.0.0.0 255.255.255.255 action cos 3
   (config-ip-qos)# exit

8.(config)# interface gigabitethernet 0/25
   (config-if)# switchport mode trunk
   (config-if)# switchport trunk allowed vlan 100,200
   (config-if)# media-type rj45
9.(config-if)# ip qos-flow-group QOS-LIST in
   (config-if)# exit

10.(config)# qos-queue-list QLIST-PQ pq

11.(config)# interface fastethernet 0/11
   (config-if)# switchport mode access
   (config-if)# switchport access vlan 100
12.(config-if)# qos-queue-group QLIST-PQ
   (config-if)# exit

13.(config)# qos-queue-list QLIST-WRR wrr

14.(config)# interface fastethernet 0/21
   (config-if)# switchport mode access
   (config-if)# switchport access vlan 200
15.(config-if)# qos-queue-group QLIST-WRR
   (config-if)# exit
```

1. Creates VLAN 100 and VLAN 200
2. Enables the receiving-side flow detection mode Layer 2-2 (flow detection specialized for IPv4)
3. Creates an IPv4 QoS flow list (QOS-LIST)
4. Sets CoS value=7 in the QOS-LIST for the frames sent from the source IP address 192.168.100.63
5. Sets CoS value=7 in the QOS-LIST for the frames sent from the source IP address 192.168.200.63
6. Sets CoS value=3 in the QOS-LIST for the frames sent from the source IP address 192.168.100.24
7. Sets CoS value=3 in the QOS-LIST for the frames sent from the source IP address 192.168.200.24
8. Sets VLAN 100 and VLAN 200 to port 0/25 as a trunk port
9. Enables the QOS-LIST for port 0/25
10. Sets the scheduling mode of PQ to the QoS queue list information (QLIST-PQ)
11. Sets VLAN 100 to port 0/11 as an access port
12. Enables QoS queue list information (QLIST-PQ) for port 0/11
13. Sets the scheduling mode of weighted round-robin in the QoS queue list information (QLIST-WRR)
14. Sets port 0/21 as the access port of VLAN 200
15. Enables the QoS queue list information (QLIST-WRR) for port 0/21

[Notes]

To use QoS flow detection on AX1230S series switches, the setting of system function resource allocation must be set to the default or QoS.

For details, see *9.1.6 Setting system function resource allocation* in the *AX1200S Software Manual Configuration Guide Vol.1*.

● Configuration content for AX1240S series switches

For the configurations in this section, there are differences in the configuration commands for setting the IPv4 QoS flow list and the flow detection conditions between AX1230S series switches and AX1240S series switches.

The lines #3 through #7 in the following configuration example are the items in question.

```
1.(config)# vlan 100,200
   (config-vlan)# exit

2.(config)# flow detection mode layer2-2

3.(config)# ip qos-flow-list QOS-LIST
4 (config-ip-qos)# qos ip host 192.168.100.63 any action cos 7
5 (config-ip-qos)# qos ip host 192.168.200.63 any action cos 7
6 (config-ip-qos)# qos ip host 192.168.100.24 any action cos 3
7 (config-ip-qos)# qos ip host 192.168.200.24 any action cos 3
   (config-ip-qos)# exit

8.(config)# interface gigabitethernet 0/25
   (config-if)# switchport mode trunk
   (config-if)# switchport trunk allowed vlan 100,200
   (config-if)# media-type rj45
9.(config-if)# ip qos-flow-group QOS-LIST in
   (config-if)# exit

10.(config)# qos-queue-list QLIST-PQ pq

11.(config)# interface fastethernet 0/11
   (config-if)# switchport mode access
   (config-if)# switchport access vlan 100
12.(config-if)# qos-queue-group QLIST-PQ
   (config-if)# exit

13.(config)# qos-queue-list QLIST-WRR wrr

14.(config)# interface fastethernet 0/21
   (config-if)# switchport mode access
   (config-if)# switchport access vlan 200
15.(config-if)# qos-queue-group QLIST-WRR
   (config-if)# exit
```

1. Creates VLAN 100 and VLAN 200
2. Enables the receiving-side flow detection mode Layer 2-2 (flow detection specialized for IPv4)
3. Creates an IPv4 QoS flow list (QOS-LIST)
4. Sets CoS value=7 in the QOS-LIST for the frames sent from the source IP address 192.168.100.63
5. Sets CoS value=7 in the QOS-LIST for the frames sent from the source IP address 192.168.200.63
6. Sets CoS value=3 in the QOS-LIST for the frames sent from the source IP address 192.168.100.24
7. Sets CoS value=3 in the QOS-LIST for the frames sent from the source IP address 192.168.200.24
8. Sets VLAN 100 and VLAN 200 to port 0/25 as a trunk port
9. Enables the QOS-LIST for port 0/25
10. Sets the scheduling mode of PQ to the QoS queue list information (QLIST-PQ)
11. Sets VLAN 100 to port 0/11 as an access port
12. Enables QoS queue list information (QLIST-PQ) for port 0/11
13. Sets the scheduling mode of weighted round-robin in the QoS queue list information (QLIST-WRR)
14. Sets port 0/21 as the access port of VLAN 200
15. Enables the QoS queue list information (QLIST-WRR) for port 0/21

[Notes]

To use QoS flow detection on AX1230S series switches, if you have not configured system function resource allocation (system function), you do not have to configure it.

For details, see 9.1.6 *Functionality that uses system function resources* in the *AX1240S Software Manual Configuration Guide Vol.1*.

[Operation command]

● AX2400S

[Shows the sending queue information of the port for which the scheduling mode pq is set]

```
AX2430S# show qos queueing 0/11
Date 2008/12/12 17:48:28 JST
NIF0/Port11 (outbound)
Max_Queue=8, Rate_limit=100Mbit/s, Burst_size= -, Qmode=pq/tail_drop
Queue1: Qlen= 0, Limit_Qlen= 32
Queue2: Qlen= 0, Limit_Qlen= 32
Queue3: Qlen= 0, Limit_Qlen= 32
Queue4: Qlen= 32, Limit_Qlen= 32
Queue5: Qlen= 0, Limit_Qlen= 32
Queue6: Qlen= 0, Limit_Qlen= 32
Queue7: Qlen= 0, Limit_Qlen= 32
Queue8: Qlen= 17, Limit_Qlen= 32
discard packets
HOL1=20395382, HOL2= 0, Tail_drop= 0
```

[Shows the sending queue information of the port for which the scheduling mode wrr is set]

```
AX2430S# show qos queueing 0/21
Date 2008/12/15 13:36:35 JST
NIF0/Port21 (outbound)
Max_Queue=8, Rate_limit=100Mbit/s, Burst_size= -, Qmode=wrr/tail_drop
Queue1: Qlen= 0, Limit_Qlen= 32
Queue2: Qlen= 0, Limit_Qlen= 32
Queue3: Qlen= 0, Limit_Qlen= 32
Queue4: Qlen= 28, Limit_Qlen= 32
Queue5: Qlen= 0, Limit_Qlen= 32
Queue6: Qlen= 0, Limit_Qlen= 32
Queue7: Qlen= 0, Limit_Qlen= 32
Queue8: Qlen= 31, Limit_Qlen= 32
discard packets
HOL1=54022690, HOL2= 0, Tail_drop= 0
```

● AX1230S

[Shows the sending queue information of the port for which the scheduling mode pq is set]

```
AX1230S# show qos queueing interface fastethernet 0/11

Date 2008/12/12 17:53:02 JST
Port 0/11 (outbound)
Status : Active
Max_Queue=8, Rate_limit=100000kbit/s, Qmode=pq/tail_drop
Queue 1: Qlen= 0, Limit_Qlen= 32
Queue 2: Qlen= 0, Limit_Qlen= 32
Queue 3: Qlen= 0, Limit_Qlen= 32
Queue 4: Qlen= 32, Limit_Qlen= 32
Queue 5: Qlen= 0, Limit_Qlen= 32
Queue 6: Qlen= 0, Limit_Qlen= 32
Queue 7: Qlen= 0, Limit_Qlen= 32
Queue 8: Qlen= 28, Limit_Qlen= 32
discard packets
HOL1= 70487578, HOL2= 0, Tail_drop= 0
```

[Shows the sending queue information of the port for which the scheduling mode wrr is set]

```
AX1230S# show qos queueing interface fastethernet 0/21

Date 2008/12/15 13:38:34 JST
Port 0/21 (outbound)
Status : Active
Max_Queue=8, Rate_limit=100000kbit/s, Qmode=wrr/tail_drop
Queue 1: Qlen= 0, Limit_Qlen= 32
Queue 2: Qlen= 0, Limit_Qlen= 32
Queue 3: Qlen= 0, Limit_Qlen= 32
Queue 4: Qlen= 17, Limit_Qlen= 32
Queue 5: Qlen= 0, Limit_Qlen= 32
Queue 6: Qlen= 0, Limit_Qlen= 32
Queue 7: Qlen= 0, Limit_Qlen= 32
Queue 8: Qlen= 30, Limit_Qlen= 32
discard packets
HOL1= 18546769, HOL2= 0, Tail_drop= 0
```

● Differences in the command execution result between AX1230S series switches and AX1240S series switches

There is no difference in the command execution result of show qos queueing between AX1230S series switches and AX1240S series switches.

1.8 DHCP snooping

This section describes the configuration examples of DHCP snooping functionality on AX1230S series switches.

[Configuration figure]

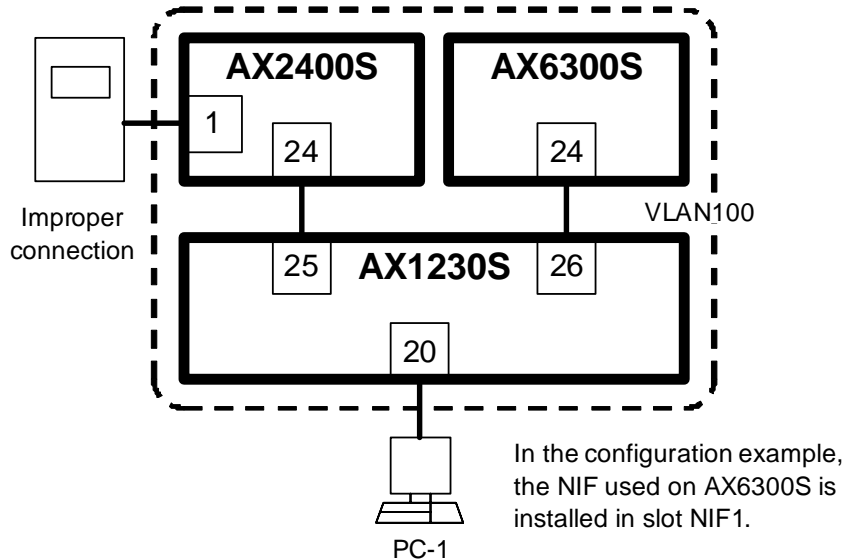

[Explanation of the configuration figure]

This is a configuration figure for DHCP snooping functionality to monitor DHCP packets from the PCs that are connected to the switch AX1230S to perform terminal filtering.

The terminal filter checks the source IP addresses and the source MAC addresses of the communication frames (except IP address allocation request frames) sent from terminals under the switch AX1230S against a binding database to discard all the frames that do not match.

When an IP address is allocated from the DHCP server, the terminal information is registered dynamically in the binding database within the switch AX1230S and the information is used in the matching process of terminal filtering. The binding database is stored in the internal flash memory of the switch AX1230S.

Configuration key points

- To use DHCP snooping, configure the following on the switch AX1230S:
 - (1) Before configuring DHCP snooping, set the system function resource allocation to DHCP snooping. Except for that on AX1240S series switches, you do not need to configure system function resource allocation (the DHCP snooping functionality can operate with the default setting).
 - (2) Enable DHCP snooping.
 - (3) Specify the VLAN# for which DHCP snooping is enabled.
 - (4) Set the port that is connected to the switch AX6300S and the switch AX2400S as a trusted port and the other ports as untrusted ports.
 - (5) Apply the terminal filter to the untrusted ports.
 - (6) Set the storage destination of the binding database to the internal flash memory.
- Assign VLAN100 to the switch AX6300S and the switch AX2400S, and assign the VLAN to the port to be used.

If you use an AX1240S series switch instead of an AX1230S series switch to build a configuration, replace the switch AX1230S in the configuration figure and in the explanation of the configuration figure with an AX1240S series switch.

[Configuration examples]

● AX6300S

```
1.(config)# vlan 100
   (config-vlan)# exit

2.(config)# interface range gigabitethernet 1/1-24
   (config-if-range)# switchport mode access
   (config-if-range)# switchport access vlan 100
   (config-if-range)# exit
```

1. Creates VLAN 100
2. Sets VLAN 100 to ports 1/1 through 1/24 as access ports

● AX2400S

```
1.(config)# vlan 100
   (config-vlan)# exit

2.(config)# interface range gigabitethernet 0/1-24
   (config-if-range)# switchport mode access
   (config-if-range)# switchport access vlan 100
   (config-if-range)# exit

   (config)# interface range gigabitethernet 0/1-4
   (config-if-range)# media-type rj45
   (config-if-range)# exit
```

1. Creates VLAN 100
2. Sets VLAN 100 to ports 0/1 through 0/24 as access ports

● AX1230S

(1) Pre-configuration

Before configuring DHCP snooping on the AX1230S series switch, you need to set the system function resource allocation to DHCP snooping.

After setting the system function resource allocation, the switch needs to be restarted.

```
1.(config)# system function dhcp-snooping
   Please execute the reload command after save,
   because this command becomes effective after reboot.

2.(config)# exit
   # copy running-config startup-config
   Do you wish to copy from running-config to startup-config? (y/n): y
   @# reload
   Restart OK? (y/n): y
```

1. Sets system function resource allocation
(When configuration is complete, messages appear to prompt you to save the configuration and restart the switch.)
2. Changes from configuration mode to the administrator mode of the switch, saves the configuration, and restarts the switch.

[Notes]

If you set the system function resource allocation only for DHCP snooping, other functions including filters and QoS will not be usable. Thus, please be careful.

For details, see 9.1.6 *Setting system function resource allocation* in the *AX1200S Software Manual Configuration Guide Vol.1*.

(2) Configuring DHCP snooping

```
1.(config)# vlan 100
   (config-vlan)# exit

2.(config)# ip dhcp snooping

3.(config)# ip dhcp snooping vlan 100

4.(config)# interface range gigabitethernet 0/25-26
   (config-if-range)# switchport mode access
   (config-if-range)# switchport access vlan 100
   (config-if-range)# media-type rj45
5.(config-if-range)# ip dhcp snooping trust
   (config-if-range)# exit

6.(config)# interface range fastethernet 0/1-24
   (config-if-range)# switchport mode access
   (config-if-range)# switchport access vlan 100
7.(config-if-range)# ip verify source port-security
   (config-if-range)# exit

8.(config)# ip dhcp snooping database url flash
```

1. Creates VLAN 100
2. Enables DHCP snooping
3. Specifies the VLAN (VLAN 100 in this example) for which DHCP snooping is to be performed
4. Sets VLAN 100 to ports 0/25 and 0/26 as access ports
5. Specifies ports 0/25 and 0/26 as trusted ports
6. Sets VLAN 100 to ports 0/1 through 0/24 as access ports
7. Applies a terminal filter for source IP address and source MAC addresses to ports 0/1 through 0/24
8. Specifies the storage destination of the binding database to the internal flash memory

● Differences in the configuration content between AX1230S series switches and series AX1240S switches

In the configuration content in this section, there is no difference between AX1230S series switches and AX1240S series switches.

Please note that, on AX1230S series switches, before configuring DHCP snooping, you need to set the system function resource allocation to DHCP snooping, but on AX1240S series switches, if the system function is not configured, you do not have to make such a configuration. Therefore, the content under the section *AX1230S (1) Pre-configuration* is not necessary.

For details, see *9.1.6 Functionality that uses system function resources* in the *AX1240S Software Manual Configuration Guide Vol.1*.

[Operation command]

● AX1230S

[Shows DHCP snooping information]

```

AX1230S# show ip dhcp snooping

Date 2008/12/12 11:50:09 JST
Switch DHCP snooping is Enable
Option allow untrusted: off, Verify mac-address: on
DHCP snooping is configured on the following VLANs:
  100
Interface           Trusted Verify source  Rate limit(pps)
fastethernet 0/1   no    port-security  unlimited
fastethernet 0/2   no    port-security  unlimited
fastethernet 0/3   no    port-security  unlimited
fastethernet 0/4   no    port-security  unlimited
fastethernet 0/5   no    port-security  unlimited
fastethernet 0/6   no    port-security  unlimited
fastethernet 0/7   no    port-security  unlimited
fastethernet 0/8   no    port-security  unlimited
fastethernet 0/9   no    port-security  unlimited
fastethernet 0/10  no    port-security  unlimited
fastethernet 0/11  no    port-security  unlimited
fastethernet 0/12  no    port-security  unlimited
fastethernet 0/13  no    port-security  unlimited
fastethernet 0/14  no    port-security  unlimited
fastethernet 0/15  no    port-security  unlimited
fastethernet 0/16  no    port-security  unlimited
fastethernet 0/17  no    port-security  unlimited
fastethernet 0/18  no    port-security  unlimited
fastethernet 0/19  no    port-security  unlimited
fastethernet 0/20  no    port-security  unlimited
fastethernet 0/21  no    port-security  unlimited
fastethernet 0/22  no    port-security  unlimited
fastethernet 0/23  no    port-security  unlimited
fastethernet 0/24  no    port-security  unlimited
gigabitethernet 0/25 yes    off            unlimited
gigabitethernet 0/26 yes    off            unlimited

```

[Shows binding database information]

```

AX1230S# show ip dhcp snooping binding

Date 2008/12/12 11:50:18 JST

Agent URL: flash
Last succeeded time: 2008/12/12 11:05:31 JST

Total Bindings: 1
MAC Address      IP Address      Expire(min) Type      VLAN  Interface
0000.e22b.ffdd  192.168.100.24  1413      dynamic  100   fastethernet
0/20

```

● Differences in the command execution result between AX1230S series switches and AX1240S series switches

There is no difference in the command execution result of show ip dhcp snooping and show ip dhcp snooping binding between AX1230S series switches and AX1240S series switches.

1.9 L2 loop detection

This section describes configuration examples of L2 loop detection functionality on AX2400S and AX1230S series switches.

[Configuration figure]

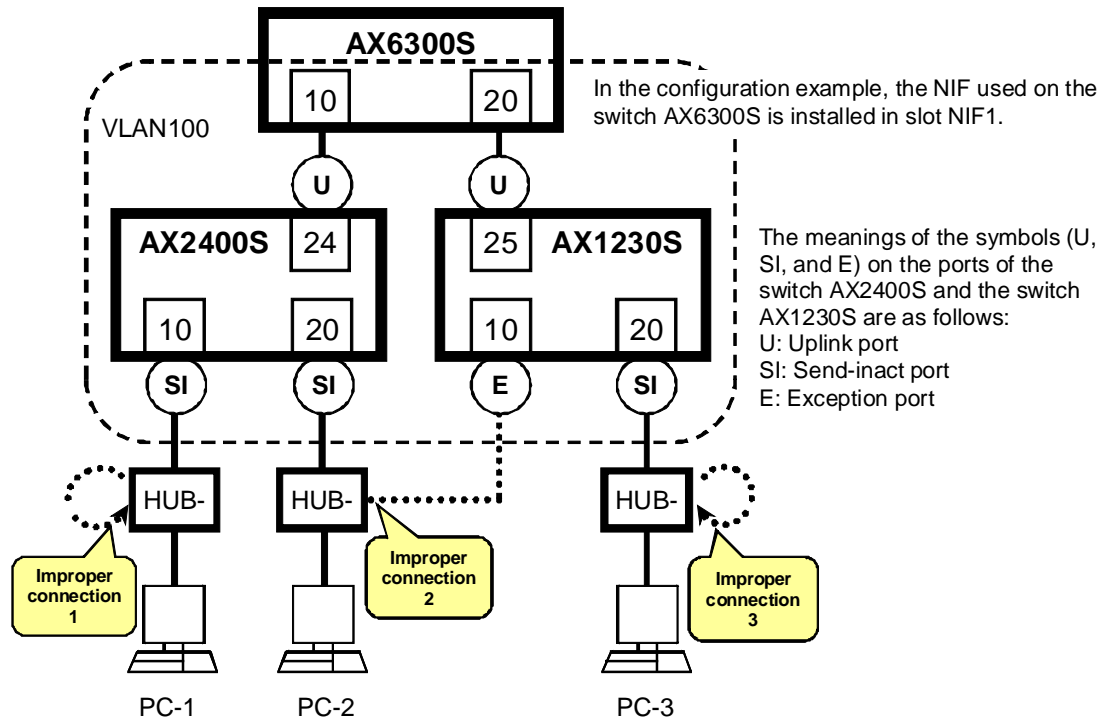

[Explanation of the configuration figure]

This is a configuration figure that performs L2 loop detection on the switch AX2400S and the switch AX1230S.

If improper connections are made as shown in the configuration figure as Improper connections 1 through 3, the following operations are made on the ports.

- Improper connection 1: The L2 loop detection frame sent from port 10 of the switch AX2400S is received on port 10 of the switch AX2400S.
 => Deactivates port 10 of the switch AX2400S
- Improper connection 2: The L2 loop detection frame sent from port 20 of the switch AX2400S is received on port 24 of the switch AX2400S.
 => Deactivates port 20 of the switch AX2400S
- Improper connection 3: The L2 loop detection frame sent from port 20 of the switch AX1230S is received on port 20 of the switch AX1230S.
 => Deactivates port 20 of the switch AX1230S

Though not described in the figure, configure the port that becomes active automatically when three minutes passes after the deactivation.

Configuration key points

- To use L2 loop detection, configure the switch AX2400S and the switch AX1230S as follows:
 - (1) Enable L2 loop detection.
 - (2) Set the lapse of time to automatically activate the port deactivated by the L2 loop detection functionality to three minutes (180 seconds).
 - (3) Set ports 10 and 20 of the switch AX2400S as send-inact ports.
 - (4) Set port 24 of the switch AX2400S as an uplink port.
 - (5) Set port 10 of the switch AX1230S as an exception port of L2 loop detection.
 - (6) Set port 20 of the switch AX1230S as a send-inact port.
 - (7) Set port 25 of the switch AX1230S as an uplink port.
- Assign VLAN 100 to the switch AX6300S, and assign the VLAN to the ports to be used.

If you use an AX1240S series switch instead of an AX1230S series switch to build a configuration, replace the switch AX1230S in the configuration figure and in the explanation of the configuration figure with an AX1240S series switch.

[Configuration examples]

● AX6300S

```
1.(config)# vlan 100
   (config-vlan)# exit

2.(config)# interface range gigabitethernet 1/1-24
   (config-if-range)# switchport mode access
   (config-if-range)# switchport access vlan 100
   (config-if-range)# exit
```

1. Creates VLAN 100
2. Sets VLAN 100 to ports 1/1 through 1/24 as access ports

● AX2400S

```
1.(config)# vlan 100
   (config-vlan)# exit

2.(config)# loop-detection enable

3.(config)# loop-detection auto-restore-time 180

4.(config)# interface range gigabitethernet 0/1-24
   (config-if-range)# switchport mode access
   (config-if-range)# switchport access vlan 100
   (config-if-range)# media-type rj45
   (config-if-range)# exit

5.(config)# interface gigabitethernet 0/10
   (config-if)# loop-detection send-inact-port
   (config-if)# exit

6.(config)# interface gigabitethernet 0/20
   (config-if)# loop-detection send-inact-port
   (config-if)# exit

7.(config)# interface gigabitethernet 0/24
   (config-if)# loop-detection uplink-port
   (config-if)# exit
```

1. Creates VLAN 100
2. Enables L2 loop detection functionality
3. Configures to automatically activate the port deactivated by L2 loop detection functionality after 180 seconds
4. Sets VLAN 100 to ports 0/1 through 0/24 as access ports
5. Sets port 0/10 as a send-inact port
6. Sets port 0/20 as a send-inact port
7. Sets port 0/24 as an uplink port

● AX1230S

```
1.(config)# vlan 100
   (config-vlan)# exit

2.(config)# loop-detection enable

3.(config)# loop-detection auto-restore-time 180

4.(config)# interface range fastethernet 0/1-24
   (config-if-range)# switchport mode access
   (config-if-range)# switchport access vlan 100
   (config-if-range)# exit

5.(config)# interface range gigabitethernet 0/25-26
   (config-if-range)# switchport mode access
   (config-if-range)# switchport access vlan 100
   (config-if-range)# media-type rj45
   (config-if-range)# exit

6.(config)# interface fastethernet 0/10
   (config-if)# loop-detection exception-port
   (config-if)# exit

7.(config)# interface fastethernet 0/20
   (config-if)# loop-detection send-inact-port
   (config-if)# exit

8.(config)# interface gigabitethernet 0/25
   (config-if)# loop-detection uplink-port
   (config-if)# exit
```

1. Creates VLAN 100 as a port VLAN
2. Enables L2 loop detection functionality
3. Configures to automatically activate the port deactivated by L2 loop detection functionality after 180 seconds
4. Sets VLAN 100 to ports 0/1 through 0/24 as access ports
5. Sets VLAN 100 to ports 0/25 through 0/26 as access ports
6. Sets port 0/10 as an exception port of L2 loop detection
7. Sets port 0/20 as a send-inact port
8. Sets port 0/25 as an uplink port

● Differences in the configuration content between AX1230S series switches and AX1240S series switches

In the configuration content in this section, there is no difference between AX1230S series switches and AX1240S series switches.

[Operation command]

● AX2400S

[Shows L2 loop detection information]

```

AX2430S# show loop-detection
Date 2008/12/11 11:16:11 JST
Interval Time          :10
Output Rate            :30pps
Threshold              :1
Hold Time              :infinity
Auto Restore Time     :180
VLAN Port Counts
  Configuration        :2          Capacity      :300
Port Information
  Port  Status  Type      DetectCnt RestoringTimer  SourcePort  Vlan
  0/1   Down    trap      0          0                - -
  0/2   Down    trap      0          0                - -
  0/3   Down    trap      0          0                - -
  0/4   Down    trap      0          0                - -
  0/5   Down    trap      0          0                - -
  0/6   Down    trap      0          0                - -
  0/7   Down    trap      0          0                - -
  0/8   Down    trap      0          0                - -
  0/9   Down    trap      0          0                - -
  0/10  Up      send-inact 0          0                - -
  0/11  Down    trap      0          0                - -
  0/12  Down    trap      0          0                - -
  0/13  Down    trap      0          0                - -
  0/14  Down    trap      0          0                - -
  0/15  Down    trap      0          0                - -
  0/16  Down    trap      0          0                - -
  0/17  Down    trap      0          0                - -
  0/18  Down    trap      0          0                - -
  0/19  Down    trap      0          0                - -
  0/20  Up      send-inact 0          0                - -
  0/21  Down    trap      0          0                - -
  0/22  Down    trap      0          0                - -
  0/23  Down    trap      0          0                - -
  0/24  Up      uplink    -          -                - -

```

● AX1230S

[Shows L2 loop detection information]

```

AX1230S# show loop-detection

Date 2008/12/11 11:17:48 JST
Interval Time      :10
Output Rate       :20pps
Threshold         :1
Hold Time         :infinity
Auto Restore Time :180
VLAN Port Counts
  Configuration   :1          Capacity   :200
Port Information
  Port  Status  Type      DetectCnt RestoringTimer SourcePort  Vlan
  0/1   Down    trap      0          0          - -
  0/2   Down    trap      0          0          - -
  0/3   Down    trap      0          0          - -
  0/4   Down    trap      0          0          - -
  0/5   Down    trap      0          0          - -
  0/6   Down    trap      0          0          - -
  0/7   Down    trap      0          0          - -
  0/8   Down    trap      0          0          - -
  0/9   Down    trap      0          0          - -
  0/10  Up       exception 0          0          - -
  0/11  Down    trap      0          0          - -
  0/12  Down    trap      0          0          - -
  0/13  Down    trap      0          0          - -
  0/14  Down    trap      0          0          - -
  0/15  Down    trap      0          0          - -
  0/16  Down    trap      0          0          - -
  0/17  Down    trap      0          0          - -
  0/18  Down    trap      0          0          - -
  0/19  Down    trap      0          0          - -
  0/20  Up       send-inact 0          0          - -
  0/21  Down    trap      0          0          - -
  0/22  Down    trap      0          0          - -
  0/23  Down    trap      0          0          - -
  0/24  Down    trap      0          0          - -
  0/25  Up       uplink    -          -          - -
  0/26  Down    trap      0          0          - -
    
```

● Differences in the command execution result between AX1230S series switches and AX1240S series switches

There is no difference in the command execution result of show loop-detection between AX1230S series switches and AX1240S series switches.

1.10 Storm control

This section describes a configuration example of storm control.

[Configuration figure]

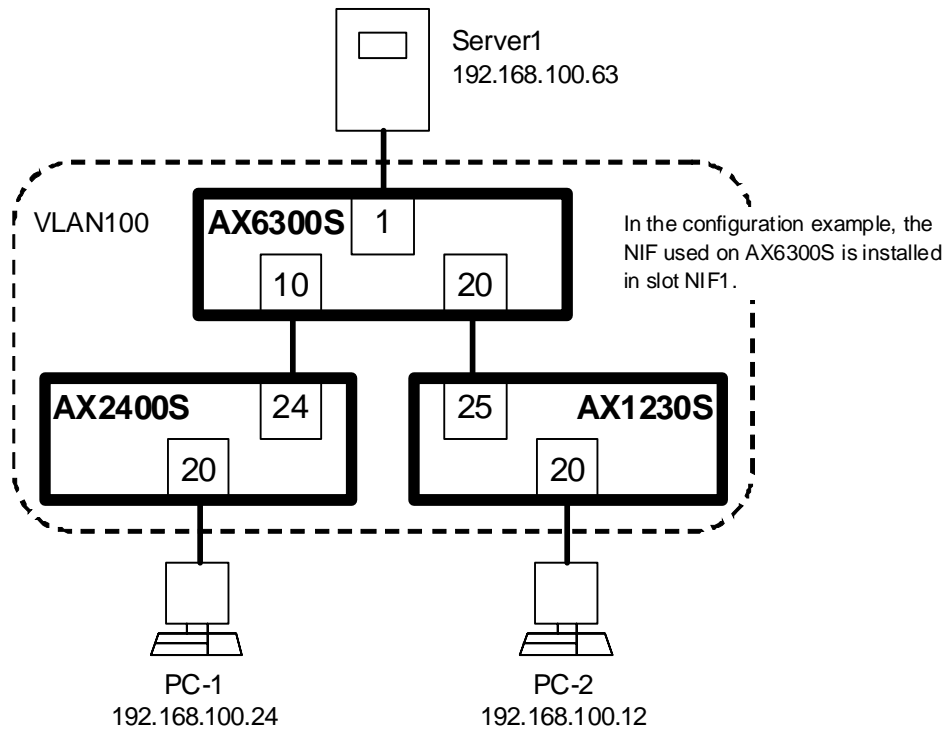

[Explanation of the configuration figure]

In the above configuration figure, storm control is performed on port 1 of the switch AX6300S, port 20 of the switch AX2400S, and port 20 of the switch AX1230S, in order to prevent excessive load on the connected devices.

When using storm control functionality, you can specify broadcast storm, multicast storm, and unicast storm individually. In this example, we describe broadcast storm.

Configuration key points

- On each switch, specify broadcast frames as the target of storm detection and set the threshold of storm occurrence.

AX6300S: (1) Perform the following configurations in global configuration mode.

1. Specify the storm control mode.

2. Unspecify multicast frames and unicast frames as the target.

This is necessary because by default all of broadcast frames, multicast frames, and unicast frames are included in the target.

- (2) Set the threshold to the target ports.

- (3) For when a storm is detected, configure operations such that they are output to the log file.

AX2400S: (1) Enable broadcast storm on the target ports and set the threshold.

- (2) For when a storm is detected, configure operations such that they are output to the log file.

AX1230S: (1) Enable broadcast storm on the target ports and set the threshold.

- (2) For when a storm is detected, configure operations such that they are output to the log file.

If you use an AX1240S series switch instead of an AX1230S switch to build a configuration, replace the switch AX1230S in the configuration figure and in the explanation of the configuration figure with the AX1240S

series switch.

[Configuration examples]

● AX6300S

```
1.(config)# vlan 100
   (config-vlan)# exit

2.(config)# upc-storm-control mode upc-in-and-storm-control

3.(config)# no storm-control multicast
4.(config)# no storm-control unicast

5.(config)# interface range gigabitethernet 1/1-24
   (config-if-range)# switchport mode access
   (config-if-range)# switchport access vlan 100
   (config-if-range)# exit

6.(config)# interface gigabitethernet 1/1
   (config-if)# storm-control level 20

7.(config-if)# storm-control action log
   (config-if)# exit
```

1. Creates VLAN 100
2. Configures the bandwidth monitoring storm control mode to perform bandwidth monitoring and storm control functionalities concurrently
3. Unspecifies multicast frames as the target of storm control
4. Unspecifies unicast frames as the target of storm control
5. Sets VLAN 100 to ports 1/1 through 1/24 as access ports
6. Sets the threshold for broadcast frames to 20 percent of the bandwidth on port 1/1
7. Configures to output a message log when a storm is detected

● AX2400S

```
1.(config)# vlan 100
   (config-vlan)# exit

2.(config)# interface range gigabitethernet 0/1-24
   (config-if-range)# switchport mode access
   (config-if-range)# switchport access vlan 100
   (config-if-range)# exit

3.(config)# interface gigabitethernet 0/20
   (config-if)# storm-control broadcast level pps 50

4.(config-if)# storm-control action log
   (config-if)# exit
```

1. Creates VLAN 100
2. Sets VLAN 100 to ports 0/1 through 0/24 as access ports
3. Sets the threshold for broadcast frames to 50 pps on port 0/20
4. Configures to output a message log when a storm is detected

● AX1230S

```
1.(config)# vlan 100
   (config-vlan)# exit

2.(config)# interface range fastethernet 0/1-24
   (config-if-range)# switchport mode access
   (config-if-range)# switchport access vlan 100
   (config-if-range)# exit

3.(config)# interface range gigabitethernet 0/25-26
   (config-if-range)# switchport mode access
   (config-if-range)# switchport access vlan 100
   (config-if-range)# media-type rj45
   (config-if-range)# exit

4.(config)# interface fastethernet 0/20
   (config-if)# storm-control broadcast level pps 50

5.(config-if)# storm-control action log
   (config-if)# exit
```

1. Creates VLAN 100
2. Sets VLAN 100 to ports 0/1 through 0/24 as access ports
3. Sets VLAN 100 to ports 0/25 through 0/26 as access ports
4. Sets the threshold for broadcast frames to 50 pps on port 0/20
5. Configures to output a message log when a storm is detected

● Differences in the configuration content between AX1230S series switches and AX1240S series switches

In the configuration content in this section, there is no difference between AX1230S series switches and AX1240S series switches.

[Operation command]

● AX6300S

[Shows protocol information for ports to check storm control settings]

```

AX6304S# show port protocol
Date 2008/12/12 13:12:37 JST
Port Counts: 48
Port Name      Type      VLAN  STP   QoS Filter  MACTbl  Ext.
1/ 1 geth1/1    Access   1     1     0           0        1  - S - - - -
1/ 2 geth1/2    Access   1     1     0           0        0  - - - - - -
1/ 3 geth1/3    Access   1     1     0           0        0  - - - - - -
1/ 4 geth1/4    Access   1     1     0           0        0  - - - - - -
1/ 5 geth1/5    Access   1     1     0           0        0  - - - - - -
1/ 6 geth1/6    Access   1     1     0           0        0  - - - - - -
1/ 7 geth1/7    Access   1     1     0           0        0  - - - - - -
1/ 8 geth1/8    Access   1     1     0           0        0  - - - - - -
1/ 9 geth1/9    Access   1     1     0           0        0  - - - - - -
1/10 geth1/10   Access   1     1     0           0        2  - - - - - -
1/11 geth1/11   Access   1     1     0           0        0  - - - - - -
1/12 geth1/12   Access   1     1     0           0        0  - - - - - -
1/13 geth1/13   Access   1     1     0           0        0  - - - - - -
1/14 geth1/14   Access   1     1     0           0        0  - - - - - -
1/15 geth1/15   Access   1     1     0           0        0  - - - - - -
1/16 geth1/16   Access   1     1     0           0        0  - - - - - -
1/17 geth1/17   Access   1     1     0           0        0  - - - - - -
1/18 geth1/18   Access   1     1     0           0        0  - - - - - -
1/19 geth1/19   Access   1     1     0           0        0  - - - - - -
1/20 geth1/20   Access   1     1     0           0        2  - - - - - -
1/21 geth1/21   Access   1     1     0           0        0  - - - - - -
1/22 geth1/22   Access   1     1     0           0        0  - - - - - -
1/23 geth1/23   Access   1     1     0           0        0  - - - - - -
1/24 geth1/24   Access   1     1     0           0        0  - - - - - -

```

● AX2400S

[Shows protocol information for ports to check storm control settings]

```

AX2430S# show port protocol
Date 2008/12/12 13:09:33 JST
Port Counts: 24
Port Name      Type      VLAN  STP   QoS Filter  MACTbl  Ext.
0/ 1 geth0/1    Access    1     1     0           0        0    - - - - -
0/ 2 geth0/2    Access    1     1     0           0        0    - - - - -
0/ 3 geth0/3    Access    1     1     0           0        0    - - - - -
0/ 4 geth0/4    Access    1     1     0           0        0    - - - - -
0/ 5 geth0/5    Access    1     1     0           0        0    - - - - -
0/ 6 geth0/6    Access    1     1     0           0        0    - - - - -
0/ 7 geth0/7    Access    1     1     0           0        0    - - - - -
0/ 8 geth0/8    Access    1     1     0           0        0    - - - - -
0/ 9 geth0/9    Access    1     1     0           0        0    - - - - -
0/10 geth0/10   Access    1     1     0           0        0    - - - - -
0/11 geth0/11   Access    1     1     0           0        0    - - - - -
0/12 geth0/12   Access    1     1     0           0        0    - - - - -
0/13 geth0/13   Access    1     1     0           0        0    - - - - -
0/14 geth0/14   Access    1     1     0           0        0    - - - - -
0/15 geth0/15   Access    1     1     0           0        0    - - - - -
0/16 geth0/16   Access    1     1     0           0        0    - - - - -
0/17 geth0/17   Access    1     1     0           0        0    - - - - -
0/18 geth0/18   Access    1     1     0           0        0    - - - - -
0/19 geth0/19   Access    1     1     0           0        0    - - - - -
0/20 geth0/20   Access    1     1     0           0        1    - - - - -
0/21 geth0/21   Access    1     1     0           0        0    - - - - -
0/22 geth0/22   Access    1     1     0           0        0    - - - - -
0/23 geth0/23   Access    1     1     0           0        0    - - - - -
0/24 geth0/24   Access    1     1     0           0        3    - - - - -
    
```

- AX1230S

[Shows protocol information for ports to check storm control settings]

```

AX1230S# show port protocol

Date 2008/12/12 13:09:22 JST
Port Counts: 26
Port  Name          Type          VLAN  STP    QoS    Filter  MACTbl  Ext.
0/1  fastether0/1      Access        1      1      0(0)   0(0)    0       - - -
0/2  fastether0/2      Access        1      1      0(0)   0(0)    0       - - -
0/3  fastether0/3      Access        1      1      0(0)   0(0)    0       - - -
0/4  fastether0/4      Access        1      1      0(0)   0(0)    0       - - -
0/5  fastether0/5      Access        1      1      0(0)   0(0)    0       - - -
0/6  fastether0/6      Access        1      1      0(0)   0(0)    0       - - -
0/7  fastether0/7      Access        1      1      0(0)   0(0)    0       - - -
0/8  fastether0/8      Access        1      1      0(0)   0(0)    0       - - -
0/9  fastether0/9      Access        1      1      0(0)   0(0)    0       - - -
0/10 fastether0/10     Access        1      1      0(0)   0(0)    0       - - -
0/11 fastether0/11     Access        1      1      0(0)   0(0)    0       - - -
0/12 fastether0/12     Access        1      1      0(0)   0(0)    0       - - -
0/13 fastether0/13     Access        1      1      0(0)   0(0)    0       - - -
0/14 fastether0/14     Access        1      1      0(0)   0(0)    0       - - -
0/15 fastether0/15     Access        1      1      0(0)   0(0)    0       - - -
0/16 fastether0/16     Access        1      1      0(0)   0(0)    0       - - -
0/17 fastether0/17     Access        1      1      0(0)   0(0)    0       - - -
0/18 fastether0/18     Access        1      1      0(0)   0(0)    0       - - -
0/19 fastether0/19     Access        1      1      0(0)   0(0)    0       - - -
0/20 fastether0/20     Access        1      1      0(0)   0(0)    1       - S -
0/21 fastether0/21     Access        1      1      0(0)   0(0)    0       - - -
0/22 fastether0/22     Access        1      1      0(0)   0(0)    0       - - -
0/23 fastether0/23     Access        1      1      0(0)   0(0)    0       - - -
0/24 fastether0/24     Access        1      1      0(0)   0(0)    0       - - -
0/25 gigaether0/25    Access        1      1      0(0)   0(0)    3       - - -
0/26 gigaether0/26    Access        1      1      0(0)   0(0)    0       - - -
I: Isolation setting  S: Storm control setting  L: LLDP setting

```

- Differences in the command execution result between AX1230S series switches and AX1240S series switches

There is no difference in the command execution result of show port protocol between AX1230S series switches and AX1240S series switches.

[Output log]

● AX6300S

[When a storm is detected]

```
AX6304S#  
12/12 14:38:25 E4 PORT GigabitEthernet1/1 25100028 1350:000000000000 NIF 1 Port  
1:storm detected.  
AX6304S#
```

[When a storm is recovered]

```
AX6304S#  
12/12 14:39:57 E4 PORT GigabitEthernet1/1 25100029 1350:000000000000 NIF 1 Port  
1:storm recovered.  
AX6304S#
```

● AX2400S

[When a broadcast storm is detected]

```
AX2430S#  
12/12 14:42:31 E4 PORT GigabitEthernet0/20 2510000a 1350:000000000000 NIF 0 Port  
20:broadcast storm detected.  
AX2430S#
```

[When a broadcast storm is recovered]

```
AX2430S#  
12/12 14:43:19 E4 PORT GigabitEthernet0/20 2510000b 1350:000000000000 NIF 0 Port  
20:broadcast storm recovered.  
AX2430S#
```

● AX1230S

[When a broadcast storm is detected]

```
AX1230S#  
WARN 08/12/12 14:45:50 PORT STORM : Port 0/20 broadcast storm detected.  
AX1230S#
```

[When a broadcast storm is recovered]

```
AX1230S#  
WARN 08/12/12 14:46:28 PORT STORM : Port 0/20 broadcast storm recovered.  
AX1230S#
```

● Differences in the output log between AX1230S series switches and AX1240S series switches

There is no difference in the output logs when a storm is detected and recovered between AX1230S series switches and AX1240S series switches.

1.11 Rings

This section describes a configuration example of a simple ring network.

[Configuration figure]

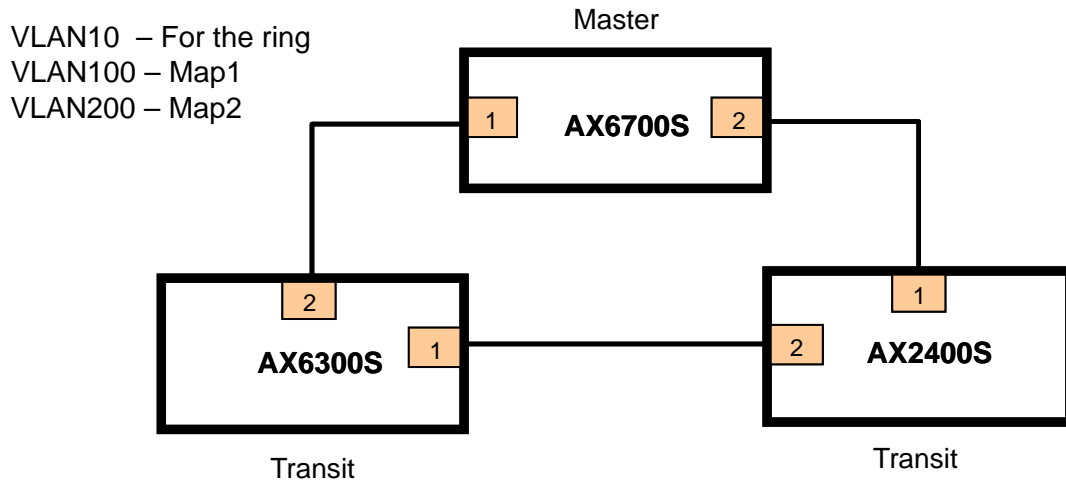

[Explanation of the configuration figure]

The ring consists of the switch AX6700S, the switch AX6300S, and the switch AX2400S.

Configuration key points

- Configure the switch AX6700S as the master node and the other switches as transit nodes.

[Related documents]

We release *AX Series ALAXALA Ring Configuration Guide* on the web as reference material that provides an overview and the basic usage of ALAXALA ring. Please consult it as necessary.
(<http://www.alaxala.com/jp/techinfo/guide/index.html#05>)

[Configuration examples]

● AX6700S

```
1. (config)# vlan 10,100,200
   (config-vlan)# exit

2. (config)# spanning-tree disable

3. (config)# interface range gigabitethernet 1/1-2
4. (config-if)# switchport mode trunk
5. (config-if)# switchport trunk allowed vlan 10,100,200
6. (config-if)# axrp-ring-port 1
   (config-if)# exit

7. (config)# axrp vlan-mapping 1 vlan 100
8. (config)# axrp vlan-mapping 2 vlan 200

9. (config)# axrp 1
10. (config-axrp)# mode master
11. (config-axrp)# control-vlan 10
12. (config-axrp)# vlan-group 1 vlan-mapping 1
13. (config-axrp)# vlan-group 2 vlan-mapping 2
    (config-axrp)# exit
```

1. Creates VLAN 10 for ring control, along with VLAN 100 and VLAN 200 for communication
2. Disables the spanning tree
3. Sets ports 1/1 and 1/2 as interfaces for the ring
4. Places the port in trunking mode
5. Adds VLAN 10 for ring control and VLAN 100 and VLAN 200 for communication to the trunk
6. Sets ports 1/1 and 1/2 as the ports for ID 1 of AXRP (AlaXala Ring Protocol)
7. Sets VLAN 100 as mapping group 1 of AXRP
8. Sets VLAN 200 as mapping group 2 of AXRP
9. Sets the AXRP ID to 1
10. Sets the switch to the master node of AXRP ID 1
11. Sets VLAN 10 as the ring control VLAN
12. Assigns VLAN mapping ID 1 to VLAN group 1
13. Assigns VLAN mapping ID 2 to VLAN group 2

● AX6300S

```
1. (config)# vlan 10,100,200
   (config-vlan)# exit

2. (config)# spanning-tree disable

3. (config)# interface range gigabitEthernet 1/1-2
4. (config-if)# switchport mode trunk
5. (config-if)# switchport trunk allowed vlan 10,100,200
6. (config-if)# axrp-ring-port 1

7. (config)# axrp vlan-mapping 1 vlan 100
8. (config)# axrp vlan-mapping 2 vlan 200

9. (config)# axrp 1
10.(config-axrp)# mode transit
11.(config-axrp)# control-vlan 10
12.(config-axrp)# vlan-group 1 vlan-mapping 1
13.(config-axrp)# vlan-group 2 vlan-mapping 2
```

1. Configures VLAN 10 for ring control, along with VLAN 100 and VLAN 200 for communication
2. Disables the spanning tree
3. Sets ports 1/1 and 1/2 as interfaces for the ring
4. Places the port in trunking mode
5. Adds VLAN 10 for ring control and VLAN 100 and VLAN 200 for communication to the trunk
6. Sets ports 1/1 and 2/2 as the ports for ID 1 of AXRP (AlaXala Ring Protocol)
7. Sets VLAN 100 as mapping group 1 of AXRP
8. Sets VLAN 200 as mapping group 2 of AXRP
9. Sets the AXRP ID to 1
10. Sets the switch to the master node of AXRP ID 1
11. Sets VLAN 10 as the ring control VLAN
12. Assigns VLAN mapping ID 1 to VLAN group 1
13. Assigns VLAN mapping ID 2 to VLAN group 2

● AX2400S

```
1. (config)# vlan 10,100,200
   (config-vlan)# exit

2. (config)# spanning-tree disable

3. (config)# interface range gigabitethernet 0/1-2
   (config-if-range)# media-type rj45
4. (config-if-range)# switchport mode trunk
5. (config-if-range)# switchport trunk allowed vlan 10,100,200
6. (config-if-range)# axrp-ring-port 1
   (config-if-range)# exit

7. (config)# axrp vlan-mapping 1 vlan 100
8. (config)# axrp vlan-mapping 2 vlan 200

9. (config)# axrp 1
10.(config-axrp)# mode master
11.(config-axrp)# control-vlan 10
12.(config-axrp)# vlan-group 1 vlan-mapping 1
13.(config-axrp)# vlan-group 2 vlan-mapping 2
   (config-axrp)# exit
```

1. Configures VLAN 10 for ring control, along with VLAN 100 and VLAN 200 for communication
2. Disables the spanning tree
3. Sets ports 1/1 and 1/2 as interfaces for the ring
4. Places the port in trunking mode
5. Adds VLAN 10 for ring control and VLAN 100 and VLAN 200 for communication to the trunk
6. Sets ports 1/1 and 2/2 as the ports for ID 1 of AXRP (AlaXala Ring Protocol)
7. Sets VLAN 100 as mapping group 1 of AXRP
8. Sets VLAN 200 as mapping group 2 of AXRP
9. Sets the AXRP ID to 1
10. Sets the switch to the master node of AXRP ID 1
11. Sets VLAN 10 as the ring control VLAN
12. Assigns VLAN mapping ID 1 to VLAN group 1
13. Assigns VLAN mapping ID 2 to VLAN group 2

[Operation command]

● AX6700S

[Ring status]

```

AX6708S# show axrp
Date 2008/11/20 16:21:29 JST

Total Ring Counts:1

Ring ID:1
Name:
Oper State:enable           Mode:Master       Attribute:-

VLAN Group ID  Ring Port  Role/State           Ring Port  Role/State
1              1/1       primary/forwarding   1/2        secondary/blocking
2              1/1       secondary/forwarding 1/2        primary/forwarding

AX6708S# show axrp detail
Date 2008/11/20 16:21:34 JST

Total Ring Counts:1

Ring ID:1
Name:
Oper State:enable           Mode:Master       Attribute:-
Control VLAN ID:10         Ring State:fault
Health Check Interval (msec):100
Health Check Hold Time (msec):256
Flush Request Counts:3

VLAN Group ID:1
VLAN ID:100
Ring Port:1/1              Role:primary      State:forwarding
Ring Port:1/2              Role:secondary    State:blocking

VLAN Group ID:2
VLAN ID:200
Ring Port:1/1              Role:secondary    State:forwarding
Ring Port:1/2              Role:primary      State:forwarding

Last Transition Time:2008/11/20 16:14:36
Fault Counts      Recovery Counts    Total Flush Request Counts
1                 0                  9

AX6708S#

```

● AX6300S

[Ring status]

```

AX6304S# show axrp
Date 2008/11/20 16:21:18 JST

Total Ring Counts:1

Ring ID:1
Name:
Oper State:enable           Mode:Transit   Attribute:-

VLAN Group ID  Ring Port  Role/State           Ring Port  Role/State
1              1/1       -/forwarding         1/2       -/forwarding
2              1/1       -/forwarding         1/2       -/forwarding

AX6304S#
AX6304S#
AX6304S# show axrp detail
Date 2008/11/20 16:21:22 JST

Total Ring Counts:1

Ring ID:1
Name:
Oper State:enable           Mode:Transit   Attribute:-
Control VLAN ID:10
Forwarding Shift Time (sec):10
Last Forwarding:forwarding shift time out

VLAN Group ID:1
VLAN ID:100
Ring Port:1/1              Role:-          State:forwarding
Ring Port:1/2              Role:-          State:forwarding

VLAN Group ID:2
VLAN ID:200
Ring Port:1/1              Role:-          State:forwarding
Ring Port:1/2              Role:-          State:forwarding

AX6304S#

```

● AX2400S

[Ring status]

```

AX2430S# show axrp
Date 2000/01/11 08:24:36 JST

Total Ring Counts:1

Ring ID:1
Name:
Oper State:enable           Mode:Transit   Attribute:-

VLAN Group ID  Ring Port  Role/State           Ring Port  Role/State
1              0/1       -/forwarding         0/2       -/forwarding
2              0/1       -/forwarding         0/2       -/forwarding

AX2430S# show axrp detail
Date 2000/01/11 08:24:39 JST

Total Ring Counts:1

Ring ID:1
Name:
Oper State:enable           Mode:Transit   Attribute:-
Control VLAN ID:10
Forwarding Shift Time (sec):10
Last Forwarding:forwarding shift time out

VLAN Group ID:1
VLAN ID:100
Ring Port:0/1              Role:-         State:forwarding
Ring Port:0/2              Role:-         State:forwarding

VLAN Group ID:2
VLAN ID:200
Ring Port:0/1              Role:-         State:forwarding
Ring Port:0/2              Role:-         State:forwarding

AX2430S#

```

2. Configuration Examples of L3 Functionalities

2.1 RIP

This section describes a configuration example that uses RIP, a basic routing protocol.

[Configuration figure]

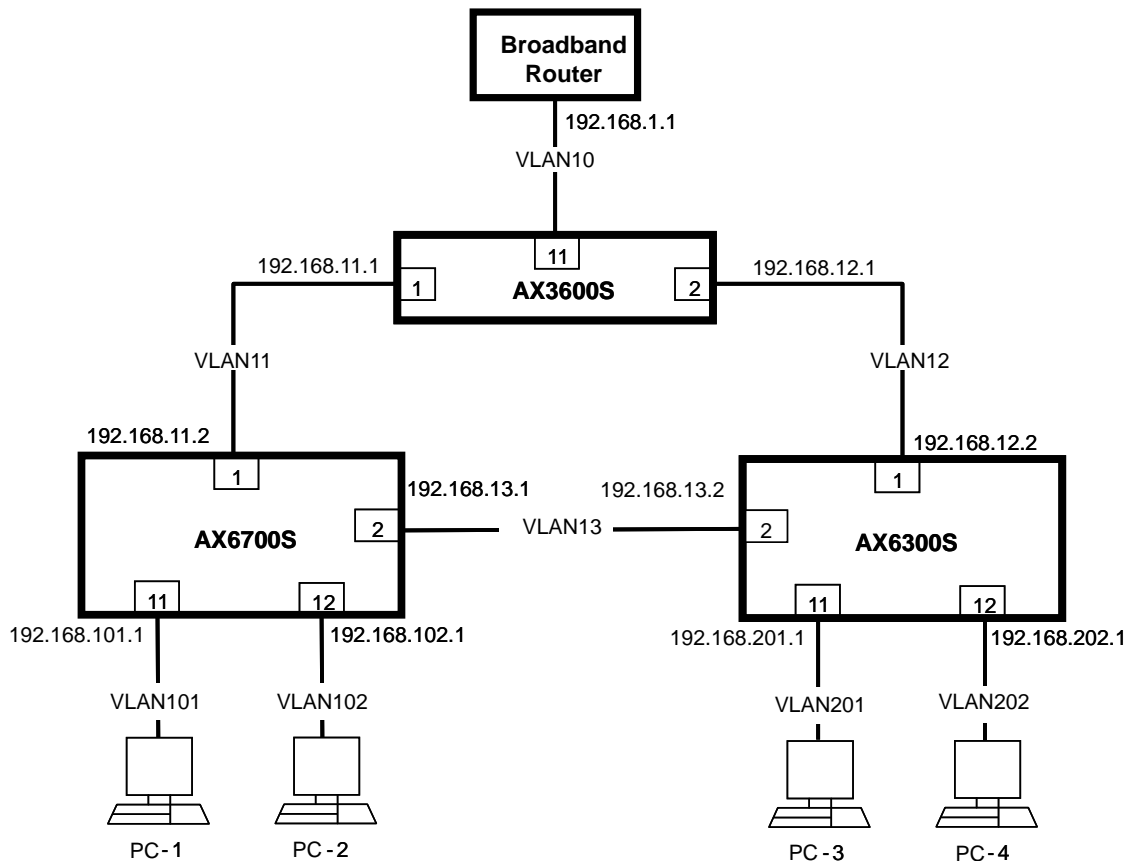

[Explanation of the configuration figure]

The switch AX3600 (which is assumed to be an externally connected router), the switch AX6700S, and the switch AX6300S exchange routing information using RIP.

Configuration key points

- The routing information is propagated from the switch AX3600S using the loopback address (which is assumed to be externally connected) as the default gateway.

[Configuration examples]

● AX6700S

```
1.(config)# vlan 11,13,101,102
   (config-vlan)# exit

2.(config)# interface gigabitethernet 1/1
   (config-if)# switchport mode access
   (config-if)# switchport access vlan 11
   (config-if)# exit

   (config)# interface gigabitethernet 1/2
   (config-if)# switchport mode access
   (config-if)# switchport access vlan 13
   (config-if)# exit

   (config)# interface gigabitethernet 1/11
   (config-if)# switchport mode access
   (config-if)# switchport access vlan 101
   (config-if)# exit

   (config)# interface gigabitethernet 1/12
   (config-if)# switchport mode access
   (config-if)# switchport access vlan 102
   (config-if)# exit

3.(config)# interface vlan 11
   (config-if)# ip address 192.168.11.2 255.255.255.0
   (config-if)# exit

   (config)# interface vlan 13
   (config-if)# ip address 192.168.13.1 255.255.255.0
   (config-if)# exit

   (config)# interface vlan 101
   (config-if)# ip address 192.168.101.1 255.255.255.0
   (config-if)# exit

   (config)# interface vlan 102
   (config-if)# ip address 192.168.102.1 255.255.255.0
   (config-if)# exit

4.(config)# router rip
5.(config-router)# version 2
6.(config-router)# network 192.168.11.0 0.0.0.255
   (config-router)# network 192.168.13.0 0.0.0.255
   (config-router)# network 192.168.101.0 0.0.0.255
   (config-router)# network 192.168.102.0 0.0.0.255
   (config-router)# exit
```

1. Configures VLAN 11, VLAN 13, VLAN 101, and VLAN 102
2. Sets VLAN 11 to port 1/1, VLAN 13 to port 1/2, VLAN 101 to port 1/11, and VLAN 102 to port 1/12
3. Assigns IP addresses and subnet masks (24-bit masks) to the VLANs
4. Enters the configuration mode using RIP as the routing protocol
5. Uses RIP Version 2
6. Sets the network information that the switches have

● AX6300S

```
1.(config)# vlan 12,13,201,202
   (config-vlan)# exit

2.(config)# interface gigabitethernet 1/1
   (config-if)# switchport mode access
   (config-if)# switchport access vlan 12
   (config-if)# exit

   (config)# interface gigabitethernet 1/2
   (config-if)# switchport mode access
   (config-if)# switchport access vlan 13
   (config-if)# exit

   (config)# interface gigabitethernet 1/11
   (config-if)# switchport mode access
   (config-if)# switchport access vlan 201
   (config-if)# exit

   (config)# interface gigabitethernet 1/12
   (config-if)# switchport mode access
   (config-if)# switchport access vlan 202
   (config-if)# exit

3.(config)# interface vlan 12
   (config-if)# ip address 192.168.12.2 255.255.255.0
   (config-if)# exit

   (config)# interface vlan 13
   (config-if)# ip address 192.168.13.2 255.255.255.0
   (config-if)# exit

   (config)# interface vlan 201
   (config-if)# ip address 192.168.201.1 255.255.255.0
   (config-if)# exit

   (config)# interface vlan 202
   (config-if)# ip address 192.168.202.1 255.255.255.0
   (config-if)# exit

4.(config)# router rip
5.(config-router)# version 2
6.(config-router)# network 192.168.12.0 0.0.0.255
   (config-router)# network 192.168.13.0 0.0.0.255
   (config-router)# network 192.168.201.0 0.0.0.255
   (config-router)# network 192.168.202.0 0.0.0.255
   (config-router)# exit
```

1. Configures VLAN 12, VLAN 13, VLAN 201, and VLAN 202
2. Sets VLAN 12 to port 1/1, VLAN 13 to port 1/2, VLAN 201 to port 1/11, and VLAN 202 to port 1/12
3. Assigns IP addresses and subnet masks (24-bit masks) to the VLANs
4. Enters the configuration mode using RIP as the routing protocol
5. Uses RIP Version 2
6. Sets the network information that the switches have

● AX3600S

```
1. (config)# vlan 10,11,12

2. (config)# interface gigabitethernet 0/1
   (config-if)# switchport mode access
   (config-if)# switchport access vlan 11
   (config-if)# exit

   (config)# interface gigabitethernet 0/2
   (config-if)# switchport mode access
   (config-if)# switchport access vlan 12
   (config-if)# exit

   (config)# interface gigabitethernet 0/11
   (config-if)# switchport mode access
   (config-if)# switchport access vlan 10
   (config-if)# exit

3. (config)# interface vlan 10
   (config-if)# ip address 192.168.1.2 255.255.255.0
   (config-if)# exit

   (config)# interface vlan 11
   (config-if)# ip address 192.168.11.1 255.255.255.0
   (config-if)# exit

   (config)# interface vlan 12
   (config-if)# ip address 192.168.12.1 255.255.255.0
   (config-if)# exit

4. (config)# router rip
5. (config-router)# version 2
6. (config-router)# redistribute static
7. (config-router)# network 192.168.11.0 0.0.0.255
   (config-router)# network 192.168.12.0 0.0.0.255
   (config-router)# exit

8. (config)# ip route 0.0.0.0 0.0.0.0 192.168.1.1
```

1. Configures VLAN 10, VLAN 11, and VLAN 12
2. Sets VLAN 11 to port 0/1, VLAN 12 to port 0/2, and VLAN 10 to port 0/11
3. Assigns IP addresses and subnet masks (24-bit masks) to the VLANs
4. Enters the configuration mode using RIP as the routing protocol
5. Uses RIP Version 2
6. Configures the static routing information (=default route) to be redistributed to RIP
7. Sets the network information that the switches have
8. Sets the default route as static

[Operation command]

● AX6700S

[Routing information]

```

AX6708S# show ip route
Date 2009/01/26 16:50:27 JST
Total: 14 routes
Destination      Next Hop          Interface         Metric   Protocol   Age
0.0.0.0/0        192.168.11.1     VLAN0011         2/0     RIP        53m 27s
127/8            ----            localhost        0/0     Connected  2h 32m
127.0.0.1/32    127.0.0.1       localhost        0/0     Connected  2h 32m
192.168.11/24   192.168.11.2     VLAN0011         0/0     Connected  1h 1m
192.168.11.2/32 192.168.11.2     VLAN0011         0/0     Connected  1h 1m
192.168.12/24   192.168.11.1     VLAN0011         2/0     RIP        1h 1m
192.168.13/24   192.168.13.1     VLAN0013         0/0     Connected  1h 34m
192.168.13.1/32 192.168.13.1     VLAN0013         0/0     Connected  1h 34m
192.168.101/24  192.168.101.1    VLAN0101         0/0     Connected  1m 52s
192.168.101.1/32 192.168.101.1    VLAN0101         0/0     Connected  1m 52s
192.168.102/24  192.168.102.1    VLAN0102         0/0     Connected  1m 52s
192.168.102.1/32 192.168.102.1    VLAN0102         0/0     Connected  1m 52s
192.168.201/24  192.168.13.2     VLAN0013         2/0     RIP        2m 5s
192.168.202/24  192.168.13.2     VLAN0013         2/0     RIP        16s
AX6708S#

```

● AX6300S

[Routing information]

```

AX6304S# show ip route
Date 2009/01/26 16:51:57 JST
Total: 14 routes
Destination      Next Hop          Interface         Metric   Protocol   Age
0.0.0.0/0        192.168.12.1     VLAN0012         2/0     RIP        57m 7s
127/8            ----            localhost        0/0     Connected  1h 38m
127.0.0.1/32    127.0.0.1       localhost        0/0     Connected  1h 38m
192.168.11/24   192.168.12.1     VLAN0012         2/0     RIP        1h 5m
192.168.12/24   192.168.12.2     VLAN0012         0/0     Connected  1h 5m
192.168.12.2/32 192.168.12.2     VLAN0012         0/0     Connected  1h 5m
192.168.13/24   192.168.13.2     VLAN0013         0/0     Connected  1h 37m
192.168.13.2/32 192.168.13.2     VLAN0013         0/0     Connected  1h 37m
192.168.101/24  192.168.13.1     VLAN0013         2/0     RIP        5m 32s
192.168.102/24  192.168.13.1     VLAN0013         2/0     RIP        3m 50s
192.168.201/24  192.168.201.1    VLAN0201         0/0     Connected  5m 46s
192.168.201.1/32 192.168.201.1    VLAN0201         0/0     Connected  5m 46s
192.168.202/24  192.168.202.1    VLAN0202         0/0     Connected  5m 46s
192.168.202.1/32 192.168.202.1    VLAN0202         0/0     Connected  5m 46s
AX6304S#

```

● AX3600S

[Routing information]

```

AX3600S# show ip route
Date 2009/01/26 16:54:57 JST
Total: 14 routes
Destination      Next Hop        Interface      Metric  Protocol  Age
0.0.0.0/0        192.168.1.1    VLAN0010       0/0     Static    55m 45s
127/8            -----        localhost      0/0     Connected 1h 4m
127.0.0.1/32     127.0.0.1      localhost      0/0     Connected 1h 4m
192.168.1/24     192.168.1.2    VLAN0010       0/0     Connected 55m 45s
192.168.1.2/32  192.168.1.2    VLAN0010       0/0     Connected 55m 45s
192.168.11/24   192.168.11.1   VLAN0011       0/0     Connected 1h 4m
192.168.11.1/32 192.168.11.1   VLAN0011       0/0     Connected 1h 4m
192.168.12/24   192.168.12.1   VLAN0012       0/0     Connected 1h 4m
192.168.12.1/32 192.168.12.1   VLAN0012       0/0     Connected 1h 4m
192.168.13/24   192.168.11.2   VLAN0011       2/0     RIP       1h 4m
192.168.101/24  192.168.11.2   VLAN0011       2/0     RIP       4m 10s
192.168.102/24  192.168.11.2   VLAN0011       2/0     RIP       2m 28s
192.168.201/24  192.168.12.2   VLAN0012       2/0     RIP       4m 23s
192.168.202/24  192.168.12.2   VLAN0012       2/0     RIP       4m 20s
AX3600S#

```

2.2 RIP filters

This section describes a configuration example that filters advertisements and receptions in networks using RIP.

(Filtering functionality is added to the configuration in the previous section.)

[Configuration figure]

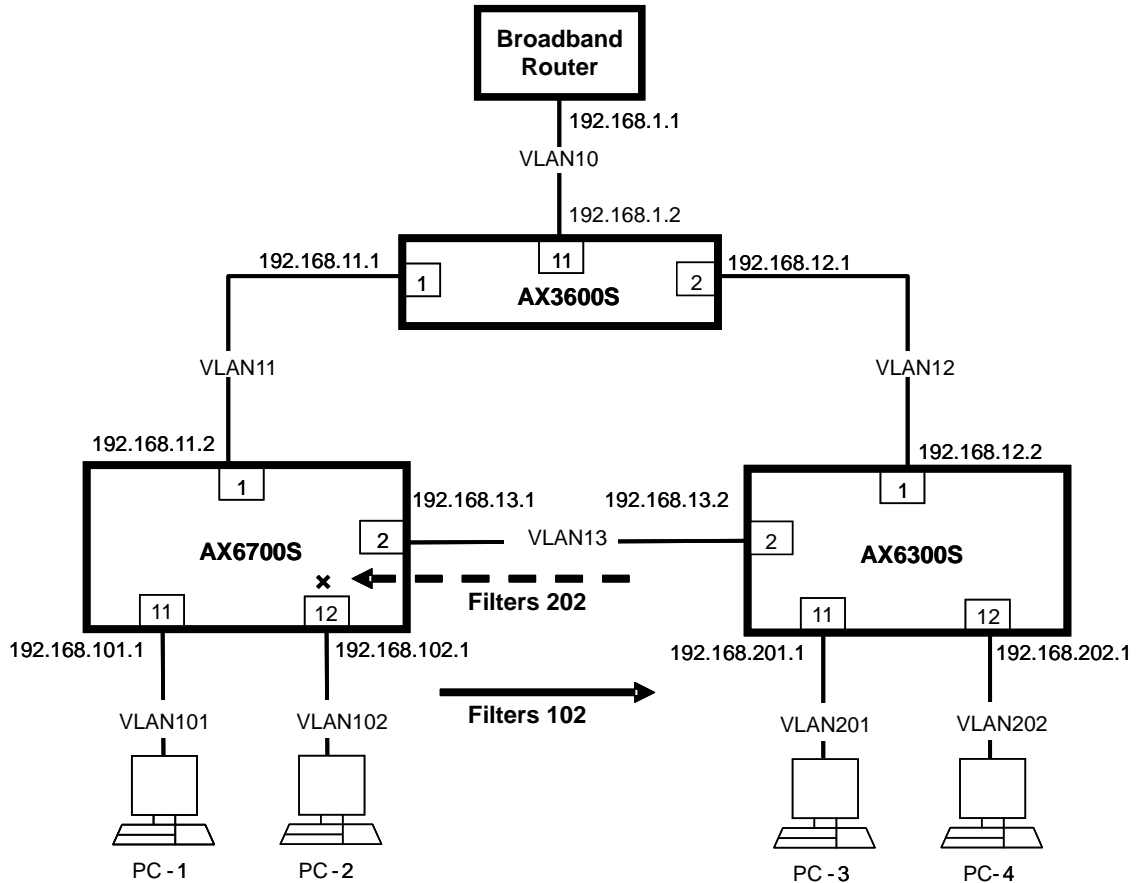

[Explanation of the configuration figure]

This example uses the same topology as the RIP configuration in the previous section.

Configuration key points

- Configure to filter, among the routes, the advertisements of VLAN 102 (192.168.102.0/24) sent from the switch AX6700S and, inversely, to filter receptions of VLAN 202 (192.168.202.0/24) sent from the switch AX6300S.

[Configuration examples]

● AX6700S (additional configuration to the previous RIP configuration)

```

1.(config)# ip prefix-list IN202 seq 10 deny 192.168.202.0/24
2.(config)# ip prefix-list IN202 seq 999 permit 0.0.0.0/0 ge 0 le 32
3.(config)# ip prefix-list OUT102 seq 10 deny 192.168.102.0/24
4.(config)# ip prefix-list OUT102 seq 999 permit 0.0.0.0/0 ge 0 le 32

5.(config)# router rip
6.(config-router)# distribute-list prefix IN202 in
7.(config-router)# distribute-list prefix OUT102 out
(config-router)# exit

```

1. Sets in the filter list IN202 that 192.168.202.0/24 is to be discarded
2. Sets in the filter list IN202 that all the other routes are to be received
3. Sets in the filter list OUT102 that 192.168.102.0/24 is to be discarded
4. Sets in the filter list OUT102 that all the other routes are to be advertised
5. Enters the configuration mode using RIP as the routing protocol
6. Configures the filter list IN202 to be applied to RIP receptions
7. Configures the filter list OUT102 to be applied to RIP advertisements

[Operation command]

● AX6700S

[Routing information]

```

AX6708S# show ip route
Date 2009/01/26 16:59:13 JST
Total: 13 routes
Destination      Next Hop          Interface         Metric   Protocol   Age
0.0.0.0/0        192.168.11.1     VLAN0011         2/0     RIP        1h 2m
127/8            ----             localhost        0/0     Connected  2h 41m
127.0.0.1/32    127.0.0.1        localhost        0/0     Connected  2h 41m
192.168.11/24    192.168.11.2     VLAN0011         0/0     Connected  1h 10m
192.168.11.2/32  192.168.11.2     VLAN0011         0/0     Connected  1h 10m
192.168.12/24    192.168.11.1     VLAN0011         2/0     RIP        1h 10m
192.168.13/24    192.168.13.1     VLAN0013         0/0     Connected  1h 43m
192.168.13.1/32  192.168.13.1     VLAN0013         0/0     Connected  1h 43m
192.168.101/24   192.168.101.1    VLAN0101         0/0     Connected  10m 38s
192.168.101.1/32 192.168.101.1    VLAN0101         0/0     Connected  10m 38s
192.168.102/24   192.168.102.1    VLAN0102         0/0     Connected  10m 38s
192.168.102.1/32 192.168.102.1    VLAN0102         0/0     Connected  10m 38s
192.168.201/24   192.168.13.2     VLAN0013         2/0     RIP        10m 51s
AX6708S#

```

● AX6300S

[Routing information]

```

AX6304S# show ip route
Date 2009/01/26 17:01:05 JST
Total: 13 routes
Destination      Next Hop          Interface          Metric   Protocol   Age
0.0.0.0/0        192.168.12.1     VLAN0012           2/0     RIP        1h 6m
127/8            -----          localhost          0/0     Connected  1h 47m
127.0.0.1/32     127.0.0.1        localhost          0/0     Connected  1h 47m
192.168.11/24    192.168.12.1     VLAN0012           2/0     RIP        1h 14m
192.168.12/24    192.168.12.2     VLAN0012           0/0     Connected  1h 14m
192.168.12.2/32  192.168.12.2     VLAN0012           0/0     Connected  1h 14m
192.168.13/24    192.168.13.2     VLAN0013           0/0     Connected  1h 46m
192.168.13.2/32  192.168.13.2     VLAN0013           0/0     Connected  1h 46m
192.168.101/24   192.168.13.1     VLAN0013           2/0     RIP        14m 40s
192.168.201/24   192.168.201.1    VLAN0201           0/0     Connected  14m 54s
192.168.201.1/32 192.168.201.1    VLAN0201           0/0     Connected  14m 54s
192.168.202/24   192.168.202.1    VLAN0202           0/0     Connected  14m 54s
192.168.202.1/32 192.168.202.1    VLAN0202           0/0     Connected  14m 54s
AX6304S#

```

● AX3600S

[Routing information]

```

AX3600S# show ip route
Date 2009/01/26 17:06:49 JST
Total: 13 routes
Destination      Next Hop          Interface          Metric   Protocol   Age
0.0.0.0/0        192.168.1.1      VLAN0010           0/0     Static     1h 7m
127/8            -----          localhost          0/0     Connected  1h 16m
127.0.0.1/32     127.0.0.1        localhost          0/0     Connected  1h 16m
192.168.1/24     192.168.1.2      VLAN0010           0/0     Connected  1h 7m
192.168.1.2/32   192.168.1.2      VLAN0010           0/0     Connected  1h 7m
192.168.11/24    192.168.11.1     VLAN0011           0/0     Connected  1h 16m
192.168.11.1/32  192.168.11.1     VLAN0011           0/0     Connected  1h 16m
192.168.12/24    192.168.12.1     VLAN0012           0/0     Connected  1h 16m
192.168.12.1/32  192.168.12.1     VLAN0012           0/0     Connected  1h 16m
192.168.13/24    192.168.11.2     VLAN0011           2/0     RIP        1h 15m
192.168.101/24   192.168.11.2     VLAN0011           2/0     RIP        16m 2s
192.168.201/24   192.168.12.2     VLAN0012           2/0     RIP        16m 15s
192.168.202/24   192.168.12.2     VLAN0012           2/0     RIP        16m 12s
AX3600S#

```

● AX6700S

[Reception routing information]

```

AX6708S# show ip rip received-routes
Date 2009/01/26 16:59:29 JST
Status Codes: * valid, > active

Neighbor Address: 192.168.11.1
  Destination      Next Hop          Interface         Metric   Tag    Timer
*> 0.0.0.0/0       192.168.11.1     VLAN0011          1        0     26s
*> 192.168.12/24   192.168.11.1     VLAN0011          1        0     26s

Neighbor Address: 192.168.13.2
  Destination      Next Hop          Interface         Metric   Tag    Timer
*> 192.168.201/24 192.168.13.2     VLAN0013          1        0     26s
AX6708S#

```

● AX6700S

[Advertisement routing information]

```

AX6708S# show ip rip advertised-routes
Date 2009/01/26 16:59:23 JST

Target Address: 192.168.11.255
Destination      Next Hop          Interface         Metric   Tag    Age
192.168.13/24    192.168.13.1     VLAN0013          1        0     1h 43m
192.168.101/24   192.168.101.1    VLAN0101          1        0     10m 47s
192.168.201/24   192.168.13.2     VLAN0013          2        0     11m 0s

Target Address: 192.168.13.255
Destination      Next Hop          Interface         Metric   Tag    Age
0.0.0.0/0        192.168.11.1     VLAN0011          2        0     1h 2m
192.168.11/24    192.168.11.2     VLAN0011          1        0     1h 10m
192.168.12/24    192.168.11.1     VLAN0011          2        0     1h 10m
192.168.101/24   192.168.101.1    VLAN0101          1        0     10m 47s

Target Address: 192.168.101.255
Destination      Next Hop          Interface         Metric   Tag    Age
0.0.0.0/0        192.168.11.1     VLAN0011          2        0     1h 2m
192.168.11/24    192.168.11.2     VLAN0011          1        0     1h 10m
192.168.12/24    192.168.11.1     VLAN0011          2        0     1h 10m
192.168.13/24    192.168.13.1     VLAN0013          1        0     1h 43m
192.168.201/24   192.168.13.2     VLAN0013          2        0     11m 0s

Target Address: 192.168.102.255
Destination      Next Hop          Interface         Metric   Tag    Age
0.0.0.0/0        192.168.11.1     VLAN0011          2        0     1h 2m
192.168.11/24    192.168.11.2     VLAN0011          1        0     1h 10m
192.168.12/24    192.168.11.1     VLAN0011          2        0     1h 10m
192.168.13/24    192.168.13.1     VLAN0013          1        0     1h 43m
192.168.101/24   192.168.101.1    VLAN0101          1        0     10m 47s
192.168.201/24   192.168.13.2     VLAN0013          2        0     11m 0s
AX6708S#

```

2.3 OSPF

This section describes a configuration example in which three L3 switches, i.e., the switch AX3600S (as an equivalent of an externally connected router), with both the switch AX6700S and the switch AX6300S as core routers, are used to perform OSPF routing. It also configures the default route information to be propagated from the switch AX3600S using OSPF.

[Configuration figure]

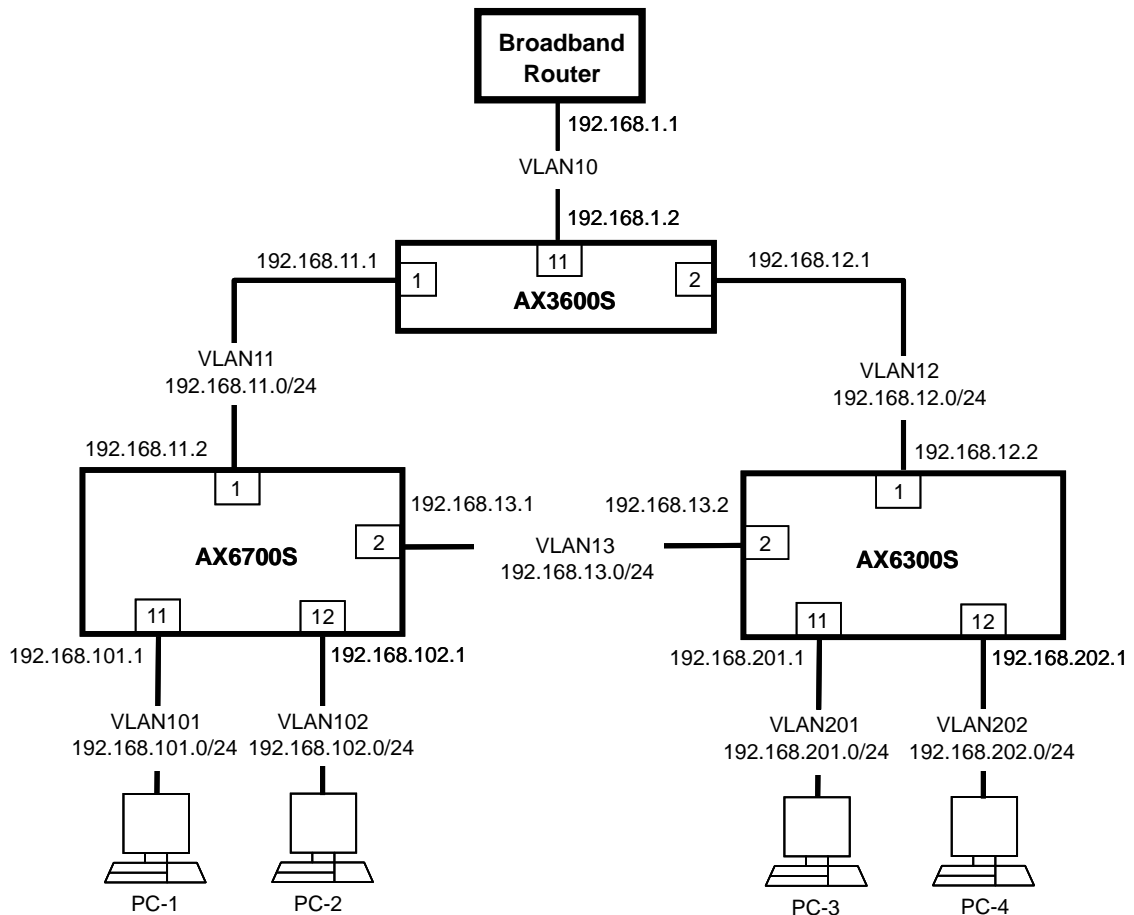

[Explanation of the configuration figure]

The configuration consists of three switches, i.e., the switch AX3600S, the switch AX6700S, and the switch AX6300S, which exchange routing information using OSPF.

Configuration key point

- The default route that is set to static is propagated from the switch AX3600S.

[Configuration examples]

● AX6700S

```
1. (config)# vlan 11,13,101,102
   (config-vlan)# exit

2. (config)# interface gigabitethernet 1/1
   (config-if)# switchport mode access
   (config-if)# switchport access vlan 11

3. (config)# interface gigabitethernet 1/2
   (config-if)# switchport mode access
   (config-if)# switchport access vlan 13

4. (config)# interface gigabitethernet 1/11
   (config-if)# switchport mode access
   (config-if)# switchport access vlan 101

5. (config)# interface gigabitethernet 1/12
   (config-if)# switchport mode access
   (config-if)# switchport access vlan 102

6. (config)# interface vlan 11
   (config-if)# ip address 192.168.11.2 255.255.255.0

   (config)# interface vlan 13
   (config-if)# ip address 192.168.13.1 255.255.255.0

   (config)# interface vlan 101
   (config-if)# ip address 192.168.101.1 255.255.255.0

   (config)# interface vlan 102
   (config-if)# ip address 192.168.102.1 255.255.255.0

7. (config)# router ospf 1

8. (config-router)# network 192.168.11.0 0.0.0.255 area 0
   (config-router)# network 192.168.13.0 0.0.0.255 area 0
   (config-router)# network 192.168.101.0 0.0.0.255 area 0
   (config-router)# network 192.168.102.0 0.0.0.255 area 0
```

1. Configures VLAN 11, VLAN 13, VLAN 101, and VLAN 102
2. Sets VLAN 11 to port 1/1 and configures it as an access port
3. Sets VLAN 13 to port 1/2 and configures it as an access port
4. Sets VLAN 101 to port 1/11 and configures it as an access port
5. Sets VLAN 102 to port 1/12 and configures it as an access port
6. Assigns IP addresses and subnet masks (24-bit masks) to the VLANs
7. Uses OSPF as the routing protocol
8. Sets the network information that the switches have

● AX6300S

```
1. (config)# vlan 12,13,201,202
   (config-vlan)# exit

2. (config)# interface gigabitethernet 1/1
   (config-if)# switchport mode access
   (config-if)# switchport access vlan 12

3. (config)# interface gigabitethernet 1/2
   (config-if)# switchport mode access
   (config-if)# switchport access vlan 13

4. (config)# interface gigabitethernet 1/11
   (config-if)# switchport mode access
   (config-if)# switchport access vlan 201

5. (config)# interface gigabitethernet 1/12
   (config-if)# switchport mode access
   (config-if)# switchport access vlan 202

6. (config)# interface vlan 12
   (config-if)# ip address 192.168.12.2 255.255.255.0

   (config)# interface vlan 13
   (config-if)# ip address 192.168.13.2 255.255.255.0

   (config)# interface vlan 201
   (config-if)# ip address 192.168.201.1 255.255.255.0

   (config)# interface vlan 202
   (config-if)# ip address 192.168.202.1 255.255.255.0

7. (config)# router ospf 1

8. (config-router)# network 192.168.12.0 0.0.0.255 area 0
   (config-router)# network 192.168.13.0 0.0.0.255 area 0
   (config-router)# network 192.168.201.0 0.0.0.255 area 0
   (config-router)# network 192.168.202.0 0.0.0.255 area 0
```

1. Configures VLAN 11 and VLAN 12
2. Sets VLAN 12 to port 1/1 and configures it as an access port
3. Sets VLAN 13 to port 1/2 and configures it as an access port
4. Sets VLAN 201 to port 1/11 and configures it as an access port
5. Sets VLAN 202 to port 1/12 and configures it as an access port
6. Assigns IP addresses and subnet masks (24-bit masks) to the VLANs
7. Uses OSPF as the routing protocol
8. Sets the network information that the switches have

● AX3600S

```
1. (config)# vlan 10,11,12
   (config-vlan)# exit

2. (config)# interface gigabitethernet 0/1
   (config-if)# switchport mode access
   (config-if)# switchport access vlan 11
   (config-if)# exit

   (config)# interface gigabitethernet 0/2
   (config-if)# switchport mode access
   (config-if)# switchport access vlan 12
   (config-if)# exit

   (config)# interface gigabitethernet 0/11
   (config-if)# switchport mode access
   (config-if)# switchport access vlan 10
   (config-if)# exit

3. (config)# interface vlan 10
   (config-if)# ip address 192.168.1.2 255.255.255.0
   (config-if)# exit

   (config)# interface vlan 11
   (config-if)# ip address 192.168.11.1 255.255.255.0
   (config-if)# exit

   (config)# interface vlan 12
   (config-if)# ip address 192.168.12.1 255.255.255.0
   (config-if)# exit

4. (config)# router ospf 1
5. (config-router)# redistribute static
6. (config-router)# network 192.168.11.0 0.0.0.255 area 0
   (config-router)# network 192.168.12.0 0.0.0.255 area 0
   (config-router)# exit

7. (config)# ip route 0.0.0.0 0.0.0.0 192.168.1.1
```

1. Configures VLAN 11 and VLAN 12
2. Sets VLAN 11 to port 1, VLAN 12 to port 2, and VLAN 10 to port 10
3. Assigns IP addresses and subnet masks (24-bit masks) to the VLANs
4. Uses OSPF as the routing protocol
5. Configures the static routing information (=default route) to be redistributed to OSPF
6. Sets the network information that the switches have
7. Sets the default route as static

[Operation command]

● AX6700S

[Shows routing information]

```

AX6708S# show ip route
Date 2009/01/26 18:13:13 JST
Total: 14 routes
Destination          Next Hop          Interface          Metric  Protocol  Age
0.0.0.0/0            192.168.11.1     VLAN0011           20/1    OSPF ext2  37m 28s
127/8                ----             localhost          0/0     Connected  51m 46s
127.0.0.1/32         127.0.0.1        localhost          0/0     Connected  51m 46s
192.168.11/24        192.168.11.2     VLAN0011           0/0     Connected  38m 14s
192.168.11.2/32      192.168.11.2     VLAN0011           0/0     Connected  38m 14s
192.168.12/24        192.168.11.1     VLAN0011           2/-     OSPF intra 37m 28s
                    192.168.13.2     VLAN0013           -       -         -
192.168.13/24        192.168.13.1     VLAN0013           0/0     Connected  40m 53s
192.168.13.1/32      192.168.13.1     VLAN0013           0/0     Connected  40m 53s
192.168.101/24       192.168.101.1    VLAN0101           0/0     Connected  45m 24s
192.168.101.1/32     192.168.101.1    VLAN0101           0/0     Connected  45m 24s
192.168.102/24       192.168.102.1    VLAN0102           0/0     Connected  44m 2s
192.168.102.1/32     192.168.102.1    VLAN0102           0/0     Connected  44m 2s
192.168.201/24       192.168.13.2     VLAN0013           2/-     OSPF intra 40m 8s
192.168.202/24       192.168.13.2     VLAN0013           2/-     OSPF intra 40m 8s
AX6708S#

```

● AX6700S

[Shows OSPF neighbors]

```

AX6708S# show ip ospf neighbor
Date 2009/01/26 18:13:18 JST
Domain: 1
Area: 0
Address          State          RouterID          Priority Interface
192.168.11.1     Full/BackupDR  192.168.1.1      1 192.168.11.2
192.168.13.2     Full/DR        192.168.202.1    1 192.168.13.1
AX6708S#

```

● AX6300S

[Shows routing information]

```

AX6304S# show ip route
Date 2009/01/26 18:15:39 JST
Total: 14 routes
Destination      Next Hop          Interface          Metric   Protocol   Age
0.0.0.0/0        192.168.12.1     VLAN0012           20/1     OSPF ext2  42m 9s
127/8            -----          localhost          0/0      Connected  45m 34s
127.0.0.1/32    127.0.0.1        localhost          0/0      Connected  45m 34s
192.168.11/24    192.168.12.1     VLAN0012           2/-      OSPF intra 42m 4s
                 192.168.13.1     VLAN0013           -        -          -
192.168.12/24    192.168.12.2     VLAN0012           0/0      Connected  42m 51s
192.168.12.2/32  192.168.12.2     VLAN0012           0/0      Connected  42m 51s
192.168.13/24    192.168.13.2     VLAN0013           0/0      Connected  45m 29s
192.168.13.2/32  192.168.13.2     VLAN0013           0/0      Connected  45m 29s
192.168.101/24   192.168.13.1     VLAN0013           2/-      OSPF intra 44m 42s
192.168.102/24   192.168.13.1     VLAN0013           2/-      OSPF intra 44m 42s
192.168.201/24   192.168.201.1    VLAN0201           0/0      Connected  45m 23s
192.168.201.1/32 192.168.201.1    VLAN0201           0/0      Connected  45m 23s
192.168.202/24   192.168.202.1    VLAN0202           0/0      Connected  45m 21s
192.168.202.1/32 192.168.202.1    VLAN0202           0/0      Connected  45m 21s
AX6304S#

```

● AX6300S

[Shows OSPF neighbor]

```

AX6304S# show ip ospf neighbor
Date 2009/01/26 18:15:45 JST
Domain: 1
Area: 0
Address          State          RouterID          Priority Interface
192.168.12.1     Full/BackupDR  192.168.1.1      1      192.168.12.2
192.168.13.1     Full/BackupDR  192.168.102.1    1      192.168.13.2
AX6304S#

```

● AX3600S

[Shows routing information]

```

AX3630S# show ip route
Date 2009/01/26 18:17:42 JST
Total: 14 routes
Destination      Next Hop          Interface          Metric   Protocol   Age
0.0.0.0/0        192.168.1.1      VLAN0010           0/0      Static     40m 30s
127/8            -----          localhost          0/0      Connected  2h 27m
127.0.0.1/32    127.0.0.1        localhost          0/0      Connected  2h 27m
192.168.1/24     192.168.1.2      VLAN0010           0/0      Connected  40m 30s
192.168.1.2/32   192.168.1.2      VLAN0010           0/0      Connected  40m 30s
192.168.11/24    192.168.11.1     VLAN0011           0/0      Connected  41m 2s
192.168.11.1/32  192.168.11.1     VLAN0011           0/0      Connected  41m 2s
192.168.12/24    192.168.12.1     VLAN0012           0/0      Connected  41m 2s
192.168.12.1/32  192.168.12.1     VLAN0012           0/0      Connected  41m 2s
192.168.13/24    192.168.11.2     VLAN0011           2/-      OSPF intra 39m 46s
                 192.168.12.2     VLAN0012           -        -          -
192.168.101/24   192.168.11.2     VLAN0011           2/-      OSPF intra 39m 46s
192.168.102/24   192.168.11.2     VLAN0011           2/-      OSPF intra 39m 46s
192.168.201/24   192.168.12.2     VLAN0012           2/-      OSPF intra 39m 51s
192.168.202/24   192.168.12.2     VLAN0012           2/-      OSPF intra 39m 51s
AX3630S#

```

● AX3600S

[Shows OSPF neighbor]

```
AX3630S# show ip ospf neighbor
Date 2009/01/26 18:17:49 JST
Domain: 1
Area: 0
Address          State          RouterID        Priority Interface
192.168.11.2    Full/DR        192.168.102.1   1    192.168.11.1
192.168.12.2    Full/DR        192.168.202.1   1    192.168.12.1
AX3630S#
```

2.4 OSPF multiple areas

This section describes a configuration example for an OSPF network that has multiple areas. (We use the same OSPF configuration as in the previous section.)

[Configuration figure]

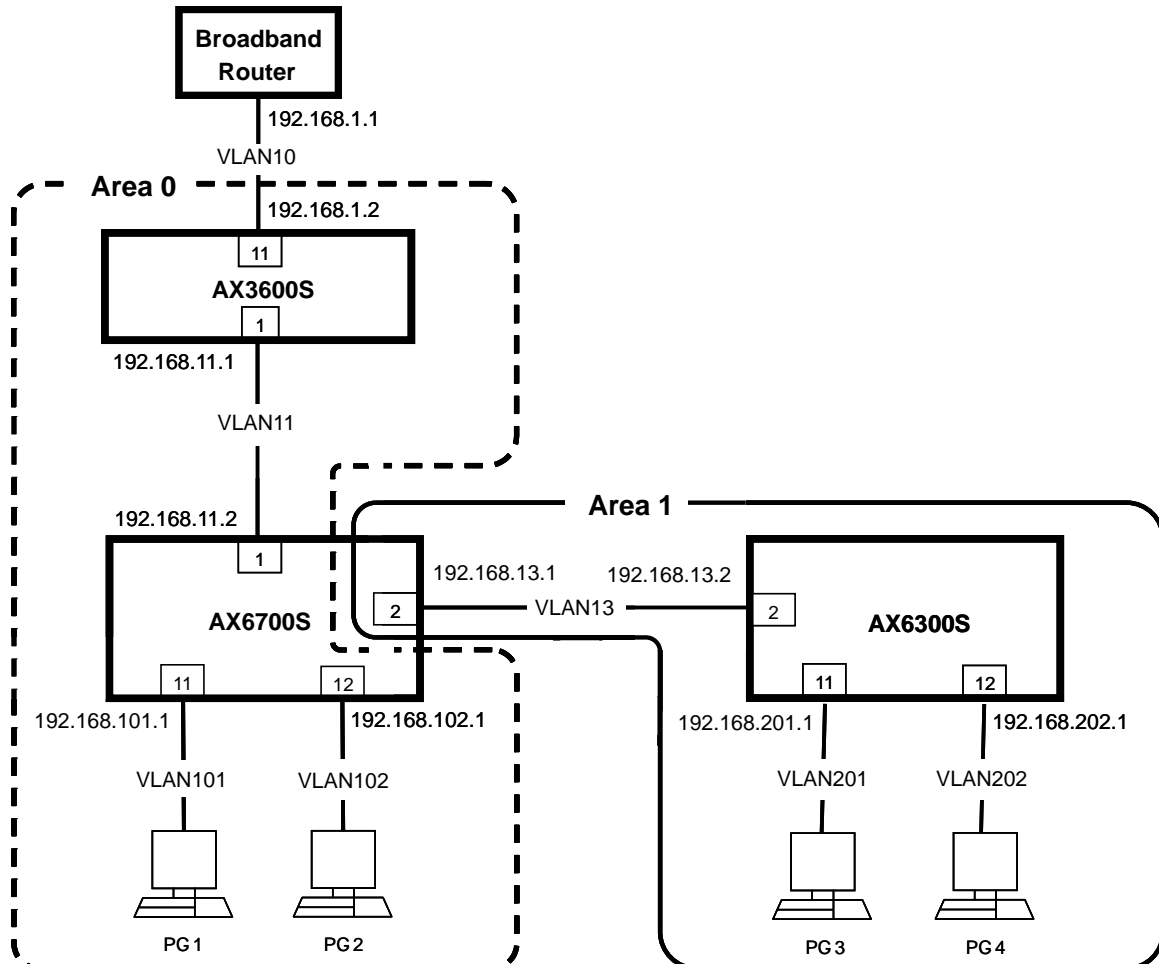

[Explanation of the configuration figure]

The switch AX3600S is assumed to be an externally connected router, and the area that contains the switch AX3600S and the switch AX6700S is specified as area 0, while the switch AX6300S and VLAN 13 (192.168.13.0/24) are specified as area 1.

Compared with the previous example (OSPF), the route between the switch AX3600S and the switch AX6300S is omitted.

Configuration key points

- Assign the switch AX6700S as the ABR (Area Border Router).

[Configuration examples]

● AX6700S

```
1.(config)# router ospf 1
2.(config-router)# network 192.168.11.0 0.0.0.255 area 0
   (config-router)# network 192.168.101.0 0.0.0.255 area 0
   (config-router)# network 192.168.102.0 0.0.0.255 area 0
3.(config-router)# network 192.168.13.0 0.0.0.255 area 1
```

1. Enters configuration mode using OSPF as the routing protocol
2. Assigns the network information of the devices that belong to area 0
3. Assigns the network information of the devices that belong to area 1

● AX6300S

```
1.(config)# router ospf 1
2.(config-router)# network 192.168.13.0 0.0.0.255 area 1
   (config-router)# network 192.168.201.0 0.0.0.255 area 1
   (config-router)# network 192.168.202.0 0.0.0.255 area 1
```

1. Enters configuration mode using OSPF as the routing protocol
2. Configures the routing information to not be sent to the interfaces
3. Configures the routing information to be sent to VLAN 13
4. Assigns the network information of the devices that belong to area 1

[Operation command]

● AX6700S

[Routing information]

```

AX6708S# show ip route
Date 2009/01/26 18:56:27 JST
Total: 13 routes
Destination      Next Hop          Interface      Metric  Protocol  Age
0.0.0.0/0        192.168.11.1     VLAN0011      20/1    OSPF ext2 13m 20s
127/8            ----            localhost     0/0     Connected 1h 35m
127.0.0.1/32    127.0.0.1       localhost     0/0     Connected 1h 35m
192.168.11/24    192.168.11.2     VLAN0011      0/0     Connected 14m 2s
192.168.11.2/32  192.168.11.2     VLAN0011      0/0     Connected 14m 2s
192.168.13/24    192.168.13.1     VLAN0013      0/0     Connected 13m 12s
192.168.13.1/32  192.168.13.1     VLAN0013      0/0     Connected 13m 12s
192.168.101/24   192.168.101.1    VLAN0101      0/0     Connected 14m 2s
192.168.101.1/32 192.168.101.1    VLAN0101      0/0     Connected 14m 2s
192.168.102/24   192.168.102.1    VLAN0102      0/0     Connected 14m 2s
192.168.102.1/32 192.168.102.1    VLAN0102      0/0     Connected 14m 2s
192.168.201/24   192.168.13.2     VLAN0013      2/-     OSPF intra 12m 0s
192.168.202/24   192.168.13.2     VLAN0013      2/-     OSPF intra 12m 0s
AX6708S#

```

● AX6300S

[Routing information]

```

AX6304S# show ip route
Date 2009/01/26 18:58:37 JST
Total: 12 routes
Destination      Next Hop          Interface      Metric  Protocol  Age
0.0.0.0/0        192.168.13.1     VLAN0013      20/2    OSPF ext2 16m 21s
127/8            ----            localhost     0/0     Connected 18m 1s
127.0.0.1/32    127.0.0.1       localhost     0/0     Connected 18m 1s
192.168.11/24    192.168.13.1     VLAN0013      2/-     OSPF inter 16m 21s
192.168.13/24    192.168.13.2     VLAN0013      0/0     Connected 16m 39s
192.168.13.2/32  192.168.13.2     VLAN0013      0/0     Connected 16m 39s
192.168.101/24   192.168.13.1     VLAN0013      2/-     OSPF inter 16m 21s
192.168.102/24   192.168.13.1     VLAN0013      2/-     OSPF inter 16m 21s
192.168.201/24   192.168.201.1    VLAN0201      0/0     Connected 16m 38s
192.168.201.1/32 192.168.201.1    VLAN0201      0/0     Connected 16m 38s
192.168.202/24   192.168.202.1    VLAN0202      0/0     Connected 16m 36s
192.168.202.1/32 192.168.202.1    VLAN0202      0/0     Connected 16m 36s
AX6304S#

```

● AX3600S

[Routing information]

```

AX3630S# show ip route
Date 2009/01/26 19:06:27 JST
Total: 12 routes
Destination      Next Hop        Interface      Metric  Protocol  Age
0.0.0.0/0        192.168.1.1    VLAN0010      0/0     Static    1h 29m
127/8            ----           localhost     0/0     Connected 3h 16m
127.0.0.1/32    127.0.0.1     localhost     0/0     Connected 3h 16m
192.168.1.1/24  192.168.1.2    VLAN0010      0/0     Connected 1h 29m
192.168.1.2/32  192.168.1.2    VLAN0010      0/0     Connected 1h 29m
192.168.11/24   192.168.11.1   VLAN0011      0/0     Connected 22m 20s
192.168.11.1/32 192.168.11.1   VLAN0011      0/0     Connected 22m 20s
192.168.13/24   192.168.11.2   VLAN0011      2/-     OSPF inter 20m 56s
192.168.101/24  192.168.11.2   VLAN0011      2/-     OSPF intra 21m 8s
192.168.102/24  192.168.11.2   VLAN0011      2/-     OSPF intra 21m 8s
192.168.201/24  192.168.11.2   VLAN0011      3/-     OSPF inter 19m 46s
192.168.202/24  192.168.11.2   VLAN0011      3/-     OSPF inter 19m 46s
AX3630S#

```

● AX6700S

[Area information]

```

AX6708S# show ip ospf area
Date 2009/01/26 18:56:41 JST
Domain: 1
ID           Neighbor  SPFcount  Flags
0            1        20        <ASBoundary>
1            1        5         <>
AX6708S#

AX6304S# show ip ospf area
Date 2009/01/26 18:59:10 JST
Domain: 1
ID           Neighbor  SPFcount  Flags
1            1        4         <>
AX6304S#

AX3630S# show ip ospf area
Date 2009/01/26 19:06:35 JST
Domain: 1
ID           Neighbor  SPFcount  Flags
0            1        14        <ASBoundary>
AX3630S#

```

● AX6700S

[OSPF database information]

```

AX6708S# show ip ospf database
Date 2009/01/26 18:57:25 JST
Domain: 1
Local Router ID :192.168.102.1
Area : 0
  LS Database: Router Link
    Router ID          LSID                ADV Router          Age  Sequence Link Count
    192.168.1.1        192.168.1.1        192.168.1.1        861  8000000D 1
    192.168.102.1     192.168.102.1     192.168.102.1     311  80000017 3
    192.168.202.1     192.168.202.1     192.168.202.1     969  8000000C 3
  LS Database: Network Link
    DR Interface        LSID                ADV Router          Age  Sequence
    192.168.11.2/24    192.168.11.2       192.168.102.1     311  80000004
    192.168.12.2/24    192.168.12.2       192.168.202.1     1467 80000004
    192.168.13.2/24    192.168.13.2       192.168.202.1     1467 80000003
  LS Database: Summary Link (Network)
    Network Address    LSID                Area Border Router Age  Sequence
    192.168.13.0/24   192.168.13.0       192.168.102.1     838  80000002
    192.168.201.0/24  192.168.201.0       192.168.102.1     778  80000001
    192.168.202.0/24  192.168.202.255    192.168.102.1     778  80000001

Area : 1
  LS Database: Router Link
    Router ID          LSID                ADV Router          Age  Sequence Link Count
    192.168.102.1     192.168.102.1     192.168.102.1     311  80000005 1
    192.168.202.1     192.168.202.1     192.168.202.1     754  80000004 3
  LS Database: Network Link
    DR Interface        LSID                ADV Router          Age  Sequence
    192.168.13.1/24    192.168.13.1       192.168.102.1     311  80000003
  LS Database: Summary Link (Network)
    Network Address    LSID                Area Border Router Age  Sequence
    192.168.11.0/24   192.168.11.0       192.168.102.1     838  80000002
    192.168.101.0/24  192.168.101.0       192.168.102.1     838  80000002
    192.168.102.0/24  192.168.102.255    192.168.102.1     838  80000002
  LS Database: Summary Link (AS Boundary Router)
    AS Boundary Router LSID                Area Border Router Age  Sequence
    192.168.1.1        192.168.1.1        192.168.102.1     838  80000002

  LS Database: AS External Link
    Network Address    LSID                AS Boundary Router Age  Sequence
    0.0.0.0/0          0.0.0.0            192.168.1.1        1470 80000003
AX6708S#

```

● AX6300S

[OSPF database information]

```

AX6304S# show ip ospf database
Date 2009/01/26 18:59:14 JST
Domain: 1
Local Router ID :192.168.202.1
Area : 1
  LS Database: Router Link
    Router ID      LSID          ADV Router    Age  Sequence Link Count
    192.168.102.1  192.168.102.1 192.168.102.1 551  80000005 1
    192.168.202.1  192.168.202.1 192.168.202.1 992  80000004 3
  LS Database: Network Link
    DR Interface   LSID          ADV Router    Age  Sequence
    192.168.13.1/24 192.168.13.1 192.168.102.1 551  80000003
  LS Database: Summary Link (Network)
    Network Address LSID          Area Border Router Age  Sequence
    192.168.11.0/24 192.168.11.0 192.168.102.1 1077 80000002
    192.168.101.0/24 192.168.101.0 192.168.102.1 1077 80000002
    192.168.102.0/24 192.168.102.255 192.168.102.1 1077 80000002
  LS Database: Summary Link (AS Boundary Router)
    AS Boundary Router LSID          Area Border Router Age  Sequence
    192.168.1.1       192.168.1.1 192.168.102.1 1077 80000002

  LS Database: AS External Link
    Network Address LSID          AS Boundary Router Age  Sequence
    0.0.0.0/0       0.0.0.0      192.168.1.1     1709 80000003
AX6304S#

```

● AX3600S

[OSPF database information]

```

AX3630S# show ip ospf database
Date 2009/01/26 19:06:39 JST
Domain: 1
Local Router ID :192.168.1.1
Area : 0
  LS Database: Router Link
    Router ID      LSID          ADV Router    Age  Sequence Link Count
    192.168.1.1    192.168.1.1 192.168.1.1 1282 8000000D 1
    192.168.102.1  192.168.102.1 192.168.102.1 734  80000017 3
    192.168.202.1  192.168.202.1 192.168.202.1 1390 8000000C 3
  LS Database: Network Link
    DR Interface   LSID          ADV Router    Age  Sequence
    192.168.11.2/24 192.168.11.2 192.168.102.1 734  80000004
    192.168.12.2/24 192.168.12.2 192.168.202.1 1889 80000004
    192.168.13.2/24 192.168.13.2 192.168.202.1 1889 80000003
  LS Database: Summary Link (Network)
    Network Address LSID          Area Border Router Age  Sequence
    192.168.13.0/24 192.168.13.0 192.168.102.1 1261 80000002
    192.168.201.0/24 192.168.201.0 192.168.102.1 1201 80000001
    192.168.202.0/24 192.168.202.255 192.168.102.1 1201 80000001
  LS Database: AS External Link
    Network Address LSID          AS Boundary Router Age  Sequence
    0.0.0.0/0       0.0.0.0      192.168.1.1     134  80000004
AX3630S#

```

2.5 VRRP

This section describes a configuration example that builds a redundant configuration between L3 switches using VRRP.

[Configuration figure]

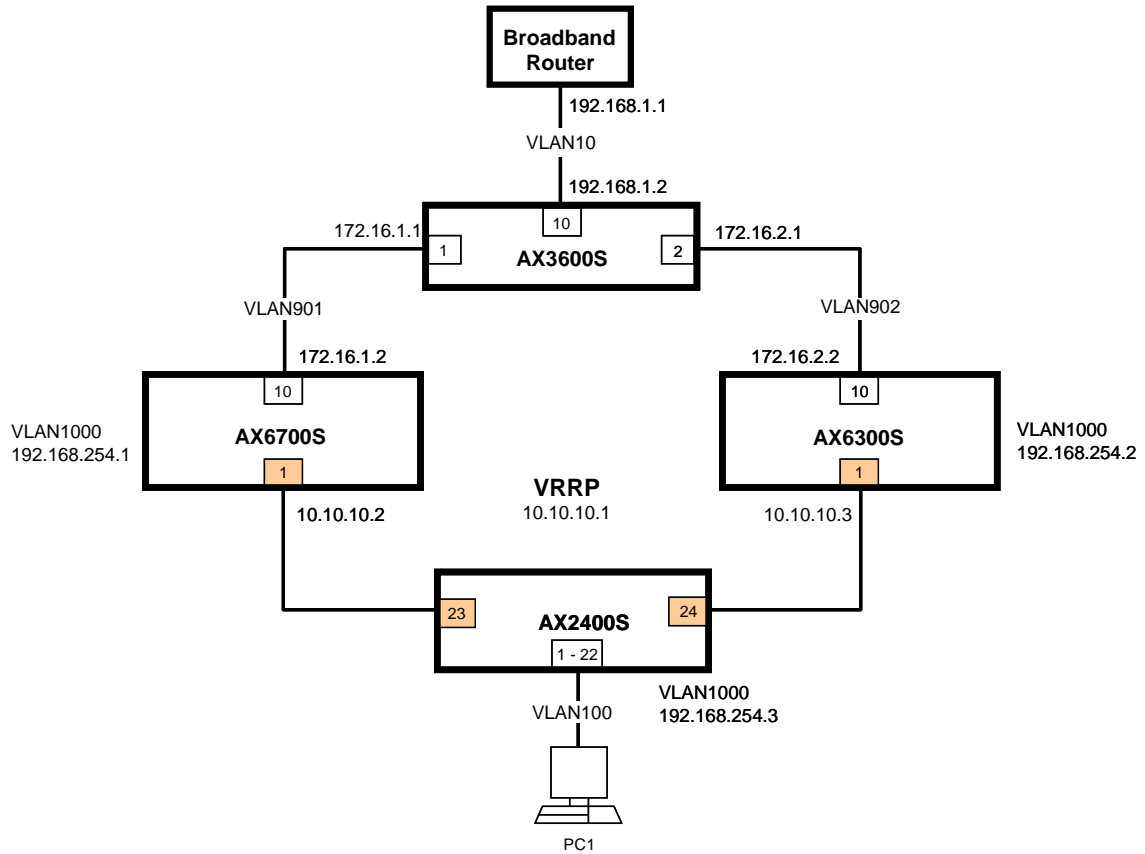

[Explanation of the configuration figure]

The switch AX6700S and the switch AX6300S form the VRRP, and the switch AX2400S is placed as the access switch.

The switch AX6700S is specified as the master of the VRRP.

Configuration key points

- Set VLAN 1000 as the management VLAN for the switches excluding the switch AX3600S.

[Configuration examples]

● AX6700S

```
1. (config)# vlan 100,901,1000
   (config-vlan)# exit

2. (config)# interface gigabitethernet 1/1
   (config-if)# switchport mode trunk
   (config-if)# switchport trunk allowed vlan 100,1000
   (config-if)# exit

   (config)# interface gigabitethernet 1/10
   (config-if)# switchport mode access
   (config-if)# switchport access vlan 901
   (config-if)# exit

3. (config)# interface vlan 100
4. (config-if)# ip address 10.10.10.2 255.255.255.0
5. (config-if)# vrrp 1 ip 10.10.10.1
6. (config-if)# vrrp 1 priority 254
7. (config-if)# vrrp 1 accept
   (config-if)# exit

8. (config)# interface vlan 901
   (config-if)# ip address 172.16.1.2 255.255.255.0
   (config-if)# exit

   (config)# interface vlan 1000
   (config-if)# ip address 192.168.254.1 255.255.255.0
   (config-if)# exit

9. (config)# router ospf 1
   (config-router)# network 10.10.10.0 0.0.0.255 area 0
   (config-router)# network 172.16.1.0 0.0.0.255 area 0
   (config-router)# exit
```

1. Configures VLAN 100 for access, VLAN 901 for superordinate access, and VLAN 1000 for management
2. Sets VLAN 100 and VLAN 1000 to port 1/1 in trunking mode and sets VLAN 901 to port 1/10 in access mode
3. Configures the interface of VLAN 100
4. Assigns the actual IP address of the VLAN interface
5. Assigns a virtual IP address used in the VRRP
6. Sets 254 as the priority so that the switch is to be the master of the VRRP
7. Configures the switch that responds to the ICMP, etc., to be sent to the virtual IP
8. Assigns IP addresses to the VLAN interfaces

● AX6300S

```
1. (config)# vlan 100,902,1000
   (config-vlan)# exit

2. (config)# interface gigabitethernet 1/1
   (config-if)# switchport mode trunk
   (config-if)# switchport trunk allowed vlan 100,1000
   (config-if)# exit

   (config)# interface gigabitethernet 1/10
   (config-if)# switchport mode access
   (config-if)# switchport access vlan 902
   (config-if)# exit

3. (config)# interface vlan 100
4. (config-if)# ip address 10.10.10.3 255.255.255.0
5. (config-if)# vrrp 1 ip 10.10.10.1
6. (config-if)# vrrp 1 accept
   (config-if)# exit

7. (config)# interface vlan 902
   (config-if)# ip address 172.16.2.2 255.255.255.0
   (config-if)# exit

   (config)# interface vlan 1000
   (config-if)# ip address 192.168.254.2 255.255.255.0
   (config-if)# exit

8. (config)# router ospf 1
   (config-router)# network 10.10.10.0 0.0.0.255 area 0
   (config-router)# network 172.16.2.0 0.0.0.255 area 0
   (config-router)# exit
```

1. Configures VLAN 100 for access, VLAN 902 for superordinate access, and VLAN 1000 for management
2. Sets VLAN 100 and VLAN 1000 to port 1/1 in trunking mode and sets VLAN 902 to port 1/10 in access mode
3. Configures the interface of VLAN 100
4. Assigns the actual IP address of the VLAN interface
5. Assigns a virtual IP address used in the VRRP
6. Configures the switch that responds to the ICMP, etc., to be sent to the virtual IP
7. Assigns IP addresses to the VLAN interfaces
8. Configures OSPF

● AX3600S

```
1. (config)# vlan 10,901,902
   (config-vlan)# exit

2. (config)# interface gigabitethernet 0/1
   (config-if)# switchport mode access
   (config-if)# switchport access vlan 901
   (config-if)# exit

   (config)# interface gigabitethernet 0/2
   (config-if)# switchport mode access
   (config-if)# switchport access vlan 902
   (config-if)# exit

   (config)# interface gigabitethernet 0/10
   (config-if)# switchport mode access
   (config-if)# switchport access vlan 10
   (config-if)# exit

3. (config)# interface vlan 10
   (config-if)# ip address 192.168.1.2 255.255.255.0
   (config-if)# exit

   (config)# interface vlan 901
   (config-if)# ip address 172.16.1.1 255.255.255.0
   (config-if)# exit

   (config)# interface vlan 902
   (config-if)# ip address 172.16.2.1 255.255.255.0
   (config-if)# exit

4. (config)# router ospf 1
5. (config-router)# redistribute static
6. (config-router)# network 172.16.1.0 0.0.0.255 area 0
   (config-router)# network 172.16.2.0 0.0.0.255 area 0
   (config-router)# exit

7. (config)# ip route 0.0.0.0 0.0.0.0 192.168.1.1
```

1. Configures VLAN 10, VLAN 901, and VLAN 902
2. Sets VLAN 901 to port 1, VLAN 902 to port 2, and VLAN 10 to port 10
3. Assigns IP addresses and subnet masks (24-bit masks) to the VLANs
4. Enters the configuration mode using OSPF as the routing protocol
5. Configures the static routing information (=default route) to be redistributed to OSPF
6. Sets the network information that the switches have
7. Sets the default route as static

● AX2400S

```
1. (config)# vlan 100,1000
   (config-vlan)# exit

2. (config)# interface range gigabitethernet 0/1-22
   (config-if)# switchport mode access
   (config-if)# switchport access vlan 100
   (config-if)# exit

3. (config)# interface range gigabitethernet 0/23-24
   (config-if)# switchport mode trunk
   (config-if)# switchport trunk allowed vlan 100,1000
   (config-if)# exit

4. (config)# interface vlan 1000
   (config-if)# ip address 192.168.254.3 255.255.255.0
   (config-if)# exit
```

1. Configures VLAN 100 for access, VLAN 902 for superordinate access, and VLAN 1000 for management
2. Sets VLAN 100 to ports 0/1 through 0/22 in access mode
3. Sets VLAN 100 and VLAN 1000 to ports 0/23 and 0/24 in trunking mode for connecting the switch AX6700S and the switch AX6300S
4. Assigns an IP address to VLAN 1000 for management

[Operation command]

● AX6700S

[Routing information]

```

AX6708S# show ip route
Date 2009/01/26 20:31:15 JST
Total: 11 routes
Destination      Next Hop          Interface          Metric   Protocol   Age
0.0.0.0/0        172.16.1.1       VLAN0901          20/1    OSPF ext2  40m 18s
10.10.10/24      10.10.10.2       VLAN0100          0/0     Connected  19m 31s
10.10.10.1/32   10.10.10.1       VLAN0100          0/0     Connected  19m 28s
10.10.10.2/32   10.10.10.2       VLAN0100          0/0     Connected  19m 31s
127/8           -----          localhost         0/0     Connected  1h 3m
127.0.0.1/32    127.0.0.1        localhost         0/0     Connected  1h 3m
172.16.1/24     172.16.1.2       VLAN0901          0/0     Connected  55m 47s
172.16.1.2/32   172.16.1.2       VLAN0901          0/0     Connected  55m 47s
172.16.2/24     10.10.10.3       VLAN0100          2/-     OSPF intra 18m 44s
                172.16.1.1       VLAN0901          -       -         -
192.168.254/24  192.168.254.1    VLAN1000          0/0     Connected  19m 31s
192.168.254.1/32 192.168.254.1    VLAN1000          0/0     Connected  19m 31s
AX6708S#

```

● AX6300S

[Routing information]

```

AX6304S# show ip route
Date 2009/01/26 20:31:16 JST
Total: 10 routes
Destination      Next Hop          Interface          Metric   Protocol   Age
0.0.0.0/0        172.16.2.1       VLAN0902          20/1    OSPF ext2  24m 30s
10.10.10/24      10.10.10.3       VLAN0100          0/0     Connected  30m 0s
10.10.10.3/32   10.10.10.3       VLAN0100          0/0     Connected  30m 0s
127/8           -----          localhost         0/0     Connected  1h 1m
127.0.0.1/32    127.0.0.1        localhost         0/0     Connected  1h 1m
172.16.1/24     10.10.10.2       VLAN0100          2/-     OSPF intra 20m 56s
                172.16.2.1       VLAN0902          -       -         -
172.16.2/24     172.16.2.2       VLAN0902          0/0     Connected  24m 44s
172.16.2.2/32   172.16.2.2       VLAN0902          0/0     Connected  24m 44s
192.168.254/24  192.168.254.2    VLAN1000          0/0     Connected  30m 0s
192.168.254.2/32 192.168.254.2    VLAN1000          0/0     Connected  30m 0s
AX6304S#

```

● AX3600S

[Routing information]

```

AX3630S# show ip route
Date 2009/01/26 20:37:23 JST
Total: 10 routes
Destination      Next Hop          Interface          Metric   Protocol   Age
0.0.0.0/0        192.168.1.1      VLAN0010          0/0     Static     44m 56s
10.10.10/24      172.16.1.2       VLAN0901          2/-     OSPF intra 23m 3s
                172.16.2.2       VLAN0902          -       -         -
127/8           -----          localhost         0/0     Connected  59m 10s
127.0.0.1/32    127.0.0.1        localhost         0/0     Connected  59m 10s
172.16.1/24     172.16.1.1       VLAN0901          0/0     Connected  57m 52s
172.16.1.1/32   172.16.1.1       VLAN0901          0/0     Connected  57m 52s
172.16.2/24     172.16.2.1       VLAN0902          0/0     Connected  32m 11s
172.16.2.1/32   172.16.2.1       VLAN0902          0/0     Connected  32m 11s
192.168.1/24    192.168.1.2      VLAN0010          0/0     Connected  55m 45s
192.168.1.2/32  192.168.1.2      VLAN0010          0/0     Connected  55m 45s
AX3630S#

```

● AX6700S

[VRRP status]

```
AX6708S# show vrrpstatus detail
Date 2009/01/26 20:31:11 JST
VLAN0100: VRID 1
  Virtual Router IP Address : 10.10.10.1
  Virtual MAC Address : 0000.5e00.0101
  Current State : MASTER
  Admin State : enable
  Priority : 254/254
  IP Address Count : 1
  Master Router's IP Address : 10.10.10.2
  Primary IP Address : 10.10.10.2
  Authentication Type : NONE
  Advertisement Interval : 1
  Preempt Mode : ON
  Preempt Delay : 0
  Non Preempt swap timer : 0
  Accept Mode : ON
  Virtual Router Up Time : Mon Jan 26 20:11:44 2009
AX6708S#
```

● AX6300S

[VRRP status]

```
AX6304S# show vrrpstatus detail
Date 2009/01/26 20:31:13 JST
VLAN0100: VRID 1
  Virtual Router IP Address : 10.10.10.1
  Virtual MAC Address : 0000.5e00.0101
  Current State : BACKUP
  Admin State : enable
  Priority : 100/100
  IP Address Count : 1
  Master Router's IP Address : 10.10.10.2
  Primary IP Address : 10.10.10.3
  Authentication Type : NONE
  Advertisement Interval : 1
  Preempt Mode : ON
  Preempt Delay : 0
  Non Preempt swap timer : 0
  Accept Mode : ON
  Virtual Router Up Time : Mon Jan 26 20:01:17 2009
AX6304S#
```

2.6 GSRP (L2/L3 linkage)

This section describes a configuration example that builds a redundant configuration between L3 switches using GSRP.

[Configuration figure]

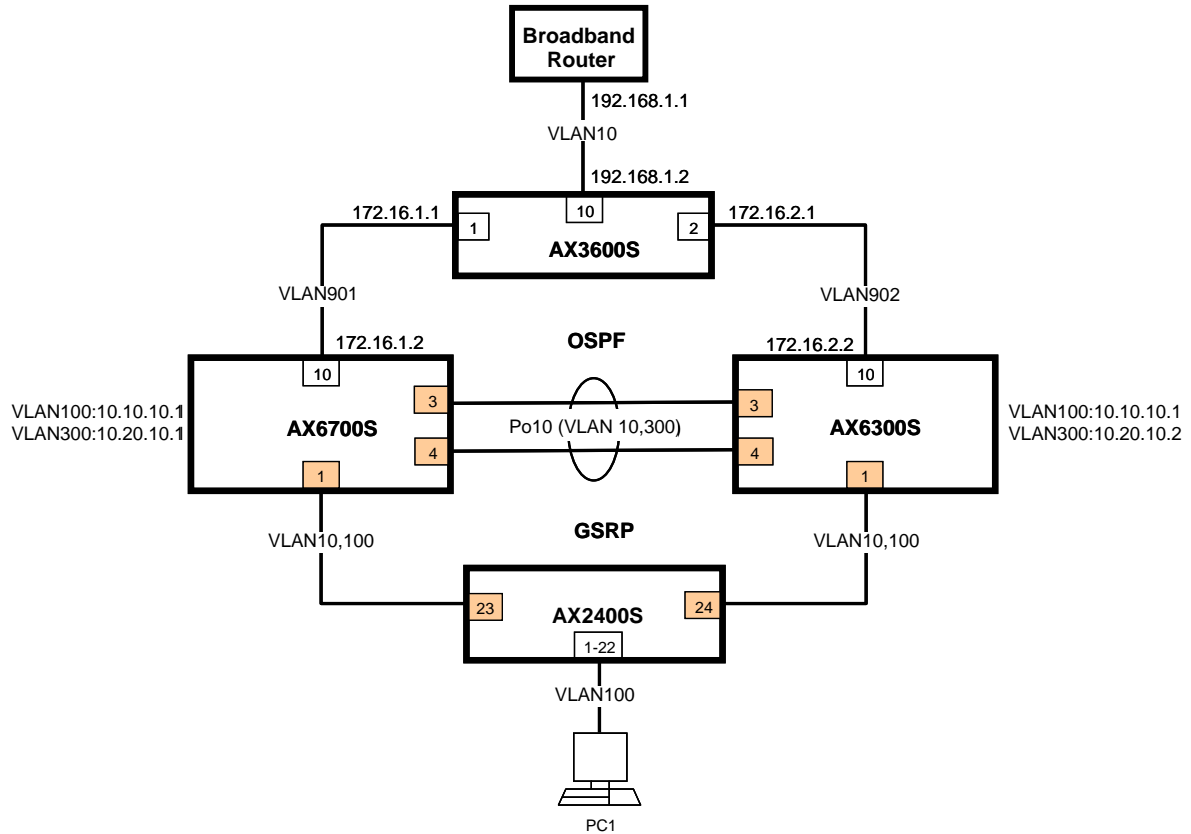

[Explanation of the configuration figure]

The switch **AX6700S** and the switch **AX6300S** form **GSRP**, and the switch **AX2400S** is placed as the access switch.

Uses **VLAN 100** for communication and **VLAN 10** for **GSRP** control.

This configuration also uses **VLAN 300** for **OSPF** communication between the two L3 switches.

Configuration key points

- Specify the switch **AX6700S** as the master of **GSRP** in **VLAN 100**.

[Configuration examples]

● AX6700S

```
1. (config)# vlan 10,100,300,901
   (config-vlan)# exit

2. (config)# spanning-tree disable

3. (config)# interface port-channel 1
   (config-if)# switchport mode trunk
   (config-if)# switchport trunk allowed vlan 10,300
   (config-if)# exit

4. (config)# interface gigabitethernet 1/1
   (config-if)# switchport mode trunk
   (config-if)# switchport trunk allowed vlan 10,100
   (config-if)# exit

5. (config)# interface range gigabitethernet 1/3-4
   (config-if-range)# switchport mode trunk
   (config-if-range)# switchport trunk allowed vlan 10,300
   (config-if-range)# channel-group 1 mode on
   (config-if)# exit

6. (config)# interface gigabitethernet 1/10
   (config-if)# switchport mode access
   (config-if)# switchport access vlan 901

7. (config-if)# gsrp exception-port
   (config-if)# exit

8. (config)# interface vlan 100
   (config-if)# ip address 10.10.10.1 255.255.255.0
   (config-if)# exit

9. (config)# interface vlan 300
   (config-if)# ip address 10.20.10.1 255.255.255.0
   (config-if)# exit

   (config)# interface vlan 901
   (config-if)# ip address 172.16.1.2 255.255.255.0
   (config-if)# exit

10.(config)# gsrp 1
11.(config-gsrp)# gsrp-vlan 10
12.(config-gsrp)# layer3-redundancy
13.(config-gsrp)# vlan-group 1 vlan 100
   (config-gsrp)# exit

14.(config)# interface port-channel 1
   (config-if)# gsrp 1 direct-link
   (config-if)# gsrp exception-port
   (config-if)# exit

15.(config)# router ospf 1
   (config-router)# network 10.10.10.0 0.0.0.255 area 0
   (config-router)# network 10.20.10.0 0.0.0.255 area 0
   (config-router)# network 172.16.1.0 0.0.0.255 area 0
   (config-rotuer)# exit
```

1. Configures VLAN 10 for GSRP, VLAN 100 for communication, VLAN 300 used between the L3 switches, and VLAN 901 for superordinate access
2. Stops the spanning tree from using GSRP
3. Prepares port channel 1 used between both the L3 switches that run GSRP
4. Assigns port 1/1 for the subordinate switch AX2400S and sets VLAN 10 for GSRP and VLAN 100 for communication as trunk ports
5. Assigns ports 1/3 and 1/4 to port channel 1
6. Assigns port 1/10 for the superordinate switch AX3600S and sets VLAN 901 for superordinate access as an access port
7. Unspecifies ports for superordinate access from the management target of GSRP
8. Assigns an IP address that is to be the default gateway from the PC to VLAN 100 for communication (It is a common IP address for both L3 switches.)
9. Assigns IP addresses to other VLAN interfaces
10. Uses GSRP
11. Configures VLAN 10 for GSRP communication
12. Configures L3 redundancy
13. Maps VLAN 100 for communication to vlan-group 1
14. Sets port channel 1 to the direct link between both L3 switches and unspecifies the port channel from the target of GSRP management
15. Sets OSPF to VLAN 100 for communication, VLAN 901 for superordinate access, and VLAN 300 used between both L3 switches

● AX6300S

```
1. (config)# vlan 10,100,300,902
   (config-vlan)# exit

2. (config)# spanning-tree disable

3. (config)# interface port-channel 1
   (config-if)# switchport mode trunk
   (config-if)# switchport trunk allowed vlan 10,300
   (config-if)# exit

4. (config)# interface gigabitethernet 1/1
   (config-if)# switchport mode trunk
   (config-if)# switchport trunk allowed vlan 10,100
   (config-if)# exit

5. (config)# interface range gigabitethernet 1/3-4
   (config-if-range)# switchport mode trunk
   (config-if-range)# switchport trunk allowed vlan 10,300
   (config-if-range)# channel-group 1 mode on
   (config-if-range)# exit

6. (config)# interface gigabitethernet 1/10
   (config-if)# switchport mode access
   (config-if)# switchport access vlan 902

7. (config-if)# gsrp exception-port
   (config-if)# exit

8. (config)# interface vlan 100
   (config-if)# ip address 10.10.10.1 255.255.255.0
   (config-if)# exit

9. (config)# interface vlan 300
   (config-if)# ip address 10.20.10.2 255.255.255.0
   (config-if)# exit

   (config)# interface vlan 902
   (config-if)# ip address 172.16.2.2 255.255.255.0
   (config-if)# exit

10.(config)# gsrp 1
11.(config-gsrp)# gsrp-vlan 10
12.(config-gsrp)# layer3-redundancy
13.(config-gsrp)# vlan-group 1 vlan 100
   (config-gsrp)# exit

14.(config)# interface port-channel 1
   (config-if)# gsrp 1 direct-link
   (config-if)# gsrp exception-port
   (config-if)# exit

15.(config)# router ospf 1
   (config-router)# network 10.10.10.0 0.0.0.255 area 0
   (config-router)# network 10.20.10.0 0.0.0.255 area 0
   (config-router)# network 172.16.2.0 0.0.0.255 area 0
   (config-router)# exit
```

1. Configures VLAN 10 for GSRP, VLAN 100 for communication, VLAN and VLAN 902 for superordinate access
2. Stops the spanning tree from using GSRP
3. Prepares port channel 1 used between both the L3 switches that run GSRP
4. Assigns port 1/1 for the subordinate switch AX2400S and sets VLAN 10 for GSRP and VLAN 100 for communication as trunk ports
5. Assigns ports 1/3 and 1/4 to port channel 1
6. Assigns port 1/10 for the superordinate switch AX3600S and sets VLAN 902 for superordinate access as an access port
7. Unspecifies ports for superordinate access from the management target of GSRP
8. Assigns an IP address that is to be the default gateway from the PC to VLAN 100 for communication (It is a common IP address for both L3 switches.)
9. Assigns IP addresses to other VLAN interfaces
10. Uses GSRP
11. Configures VLAN 10 for GSRP communication
12. Configures L3 redundancy
13. Maps VLAN 100 for communication to vlan-group 1
14. Sets port channel 1 to the direct link between both L3 switches and unspecifies the port channel from the target of GSRP management
15. Sets OSPF to VLAN 100 for communication, VLAN 901 for superordinate access, and VLAN 300 used between both L3 switches

● AX3600S

```
1. (config)# vlan 10,901,902
   (config-vlan)# exit

2. (config)# interface gigabitethernet 0/1
   (config-if)# switchport mode access
   (config-if)# switchport access vlan 901
   (config-if)# exit

   (config)# interface gigabitethernet 0/2
   (config-if)# switchport mode access
   (config-if)# switchport access vlan 902
   (config-if)# exit

   (config)# interface gigabitethernet 0/10
   (config-if)# switchport mode access
   (config-if)# switchport access vlan 10
   (config-if)# exit

3. (config)# interface vlan 10
   (config-if)# ip address 192.168.1.2 255.255.255.0
   (config-if)# exit

   (config)# interface vlan 901
   (config-if)# ip address 172.16.1.1 255.255.255.0
   (config-if)# exit

   (config)# interface vlan 902
   (config-if)# ip address 172.16.2.1 255.255.255.0
   (config-if)# exit

4. (config)# router ospf 1
5. (config-router)# redistribute static
6. (config-router)# network 172.16.1.0 0.0.0.255 area 0
   (config-router)# network 172.16.2.0 0.0.0.255 area 0
   (config-router)# exit

7. (config)# ip route 0.0.0.0 0.0.0.0 192.168.1.1
```

1. Configures VLAN 10, VLAN 901, and VLAN 902
2. Sets VLAN 901 to port 1, VLAN 902 to port 2, and VLAN 10 to port 10
3. Assigns IP addresses and subnet masks (24-bit masks) to the VLANs
4. Enters the configuration mode using OSPF as the routing protocol
5. Configures the static routing information (=default route) to be redistributed to OSPF
6. Sets the network information that the switches have
7. Sets the default route as static

● AX2400S

```
1.(config)#vlan 10,100
   (config-vlan)# exit

2.(config)#spanning-tree disable

3.(config)#interface range gigabitethernet 0/1-22
   (config-if-range)#switchport mode access
   (config-if-range)#switchport access vlan 100

4.(config)#interface range gigabitethernet 0/23-24
   (config-if-range)#switchport mode trunk
   (config-if-range)#switchport trunk allowed vlan 10,100
```

1. Configures VLAN 10 for GSRP and VLAN 100 for communication
2. Stops the spanning tree from using GSRP
3. Sets ports 0/1 through 0/22 as ports for communication with the PC and places VLAN 100 in access mode
4. Configures ports 0/23 and 0/24 to be used as the access ports of the superordinate L3 switch, and so that VLAN 10 is for GSRP and so that VLAN 100 communicates in trunking mode

[Operation command]

● AX6700S

[Routing information]

```

AX6708S# show ip route
Date 2009/01/26 20:51:01 JST
Total: 10 routes
Destination      Next Hop          Interface          Metric  Protocol  Age
0.0.0.0/0        172.16.1.1       VLAN0901           20/1   OSPF ext2  11m 47s
10.10.10/24      10.10.10.1       VLAN0100           0/0    Connected  15m 21s
10.10.10.1/32    10.10.10.1       VLAN0100           0/0    Connected  15m 21s
10.20.10/24      10.20.10.1       VLAN0300           0/0    Connected  16m 33s
10.20.10.1/32    10.20.10.1       VLAN0300           0/0    Connected  16m 33s
127/8            -----          localhost          0/0    Connected  31m  5s
127.0.0.1/32    127.0.0.1        localhost          0/0    Connected  31m  5s
172.16.1/24      172.16.1.2       VLAN0901           0/0    Connected  13m 34s
172.16.1.2/32    172.16.1.2       VLAN0901           0/0    Connected  13m 34s
172.16.2/24      10.20.10.2       VLAN0300           2/-    OSPF intra 12m 51s
                  172.16.1.1       VLAN0901           -      -          -
AX6708S#

```

● AX6300S

[Routing information]

```

AX6304S# show ip route
Date 2009/01/26 20:53:57 JST
Total: 9 routes
Destination      Next Hop          Interface          Metric  Protocol  Age
0.0.0.0/0        172.16.2.1       VLAN0902           20/1   OSPF ext2  7m 19s
10.10.10/24      10.20.10.1       VLAN0300           2/-    OSPF intra 10m 51s
10.20.10/24      10.20.10.2       VLAN0300           0/0    Connected  12m  5s
10.20.10.2/32    10.20.10.2       VLAN0300           0/0    Connected  12m  5s
127/8            -----          localhost          0/0    Connected  19m 41s
127.0.0.1/32    127.0.0.1        localhost          0/0    Connected  19m 41s
172.16.1/24      10.20.10.1       VLAN0300           2/-    OSPF intra 7m 49s
                  172.16.2.1       VLAN0902           -      -          -
172.16.2/24      172.16.2.2       VLAN0902           0/0    Connected  8m 32s
172.16.2.2/32    172.16.2.2       VLAN0902           0/0    Connected  8m 32s
AX6304S#

```

● AX3600S

[Routing information]

```

AX3630S# show ip route
Date 2009/01/26 20:54:42 JST
Total: 11 routes
Destination      Next Hop          Interface          Metric  Protocol  Age
0.0.0.0/0        192.168.1.1      VLAN0010           0/0    Static    1h  2m
10.10.10/24      172.16.1.2       VLAN0901           2/-    OSPF intra 5m 14s
10.20.10/24      172.16.1.2       VLAN0901           2/-    OSPF intra 9m  9s
127/8            -----          localhost          0/0    Connected  1h 16m
127.0.0.1/32    127.0.0.1        localhost          0/0    Connected  1h 16m
172.16.1/24      172.16.1.1       VLAN0901           0/0    Connected  9m 59s
172.16.1.1/32    172.16.1.1       VLAN0901           0/0    Connected  9m 59s
172.16.2/24      172.16.2.1       VLAN0902           0/0    Connected  10m 27s
172.16.2.1/32    172.16.2.1       VLAN0902           0/0    Connected  10m 27s
192.168.1/24     192.168.1.2      VLAN0010           0/0    Connected  1h 13m
192.168.1.2/32  192.168.1.2      VLAN0010           0/0    Connected  1h 13m
AX3630S#
192.168.1.2/32  192.168.1.2      VLAN0010           0/0    Connected  1h
13m

```

● AX6700S
[OSPF status]

```

AX6708S# show ip ospf database
Date 2008/12/09 14:21:58 JST
Domain: 1
Local Router ID :172.16.1.2
Area : 0
  LS Database: Router Link
    Router ID      LSID              ADV Router        Age  Sequence Link Count
    1.1.1.1        1.1.1.1          1.1.1.1          459 8000000C 2
    172.16.1.2     172.16.1.2       172.16.1.2       646 80000011 3
    172.16.2.2     172.16.2.2       172.16.2.2       647 8000000D 1
  LS Database: Network Link
    DR Interface    LSID              ADV Router        Age  Sequence
    10.20.10.1/24  10.20.10.1       172.16.1.2       1493 80000006
    172.16.1.1/24  172.16.1.1       1.1.1.1          459 80000008

  LS Database: AS External Link
    Network Address  LSID              AS Boundary Router Age  Sequence
    0.0.0.0/0        0.0.0.0          1.1.1.1          747 80000008
AX6708S#

```

● AX6300S
[OSPF status]

```

AX6304S# show ip ospf database
Date 2008/12/09 14:18:41 JST
Domain: 1
Local Router ID :172.16.2.2
Area : 0
  LS Database: Router Link
    Router ID      LSID              ADV Router        Age  Sequence Link Count
    1.1.1.1        1.1.1.1          1.1.1.1          366 8000000C 2
    172.16.1.2     172.16.1.2       172.16.1.2       554 80000011 3
    172.16.2.2     172.16.2.2       172.16.2.2       553 8000000D 1
  LS Database: Network Link
    DR Interface    LSID              ADV Router        Age  Sequence
    10.20.10.1/24  10.20.10.1       172.16.1.2       1401 80000006
    172.16.1.1/24  172.16.1.1       1.1.1.1          366 80000008

  LS Database: AS External Link
    Network Address  LSID              AS Boundary Router Age  Sequence
    0.0.0.0/0        0.0.0.0          1.1.1.1          654 80000008
AX6304S#

```

● AX3600S
[OSPF status]

```

AX3630S# show ip ospf database
Date 2000/01/20 08:04:35 JST
Domain: 1
Local Router ID :1.1.1.1
Area : 0
  LS Database: Router Link
    Router ID      LSID              ADV Router      Age  Sequence Link Count
    1.1.1.1        1.1.1.1          1.1.1.1        292  8000000C  2
    172.16.1.2     172.16.1.2      172.16.1.2     482  80000011  3
    172.16.2.2     172.16.2.2      172.16.2.2     483  8000000D  1
  LS Database: Network Link
    DR Interface   LSID              ADV Router      Age  Sequence
    10.20.10.1/24  10.20.10.1       172.16.1.2     1329 80000006
    172.16.1.1/24  172.16.1.1       1.1.1.1        292  80000008

  LS Database: AS External Link
    Network Address  LSID              AS Boundary Router Age  Sequence
    0.0.0.0/0        0.0.0.0          1.1.1.1        580  80000008
AX3630S#

```

● AX6700S
[GSRP status]

```

AX6708S# show gsrp detail
Date 2009/01/26 20:50:57 JST

GSRP ID: 1
Local MAC Address      : 0012.e2e0.1400
Neighbor MAC Address   : 0012.e2a0.6800
Total VLAN Group Counts : 1
GSRP VLAN ID          : 10
Direct Port           : 1/3-4
Limit Control         : Off
GSRP Exception Port   : 1/3-4,10
No Neighbor To Master : manual
Backup Lock           : disable
Port Up Delay         : 0
Last Flush Receive Time : -
Forced Shift Time     : -
Layer 3 Redundancy    : On
Virtual Link ID       : -

Advertise Hold Time      Local          Neighbor
Advertise Hold Timer    : 5              5
Advertise Interval      : 1              1
Selection Pattern       : ports-priority-mac ports-priority-mac

VLAN Group ID   Local State   Neighbor State
1                Master         Backup
    
```

● AX6300S

[GSRP status]

```

AX6304S# show gsrp detail
Date 2009/01/26 20:53:53 JST

GSRP ID: 1
Local MAC Address      : 0012.e2a0.6800
Neighbor MAC Address   : 0012.e2e0.1400
Total VLAN Group Counts : 1
GSRP VLAN ID          : 10
Direct Port            : 1/3-4
Limit Control          : Off
GSRP Exception Port    : 1/3-4,10
No Neighbor To Master  : manual
Backup Lock            : disable
Port Up Delay          : 0
Last Flush Receive Time : -
Forced Shift Time      : -
Layer 3 Redundancy     : On
Virtual Link ID        : -

Advertise Hold Time    : 5                Local           Neighbor
Advertise Hold Timer   : 5                5
Advertise Interval     : 1                -
Selection Pattern      : ports-priority-mac  ports-priority-mac  1

VLAN Group ID  Local State  Neighbor State
1              Backup      Master
    
```

● AX2400S

[GSRP status]

```

AX2430S# show gsrp aware
Date 2009/01/26 20:59:25 JST

Last MAC Address Table Flush Time      : 2009/01/26 20:47:00
GSRP Flush Request Parameters :
GSRP ID : 1      VLAN Group ID : 1      Port : 0/23
Source MAC Address : 0012.e2e0.1400

AX2430S#
    
```

3. Configuration Examples of Other Network Functionalities

3.1 DHCP

This section describes the DHCP server functionality that automatically allocates IP addresses and functionality as a relay.

[Configuration figure]

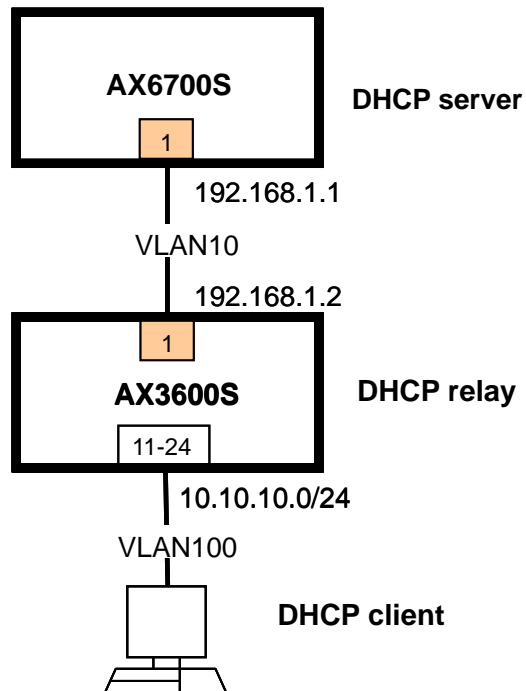

[Explanation of the configuration figure]

Configure the switch AX6700S as the DHCP server and the switch AX3600S as the DHCP relay switch.

Configuration key points

- The switch AX6700S provides DHCP service to the VLAN under the switch AX3600S, which is not connected directly.
For this purpose, reachability from the switch AX6700S to the network that requests DHCP service is required.

[Configuration examples]

● AX6700S

```
1. (config)# vlan 10
   (config-vlan)# exit

2. (config)# interface gigabitethernet 1/1
   (config-if)# switchport mode access
   (config-if)# switchport access vlan 10
   (config-if)# exit

3. (config)# interface vlan 10
   (config-if)# ip address 192.168.1.1 255.255.255.0
   (config-if)# exit

4. (config)# ip route 10.10.10.0 255.255.255.0 192.168.1.2

5. (config)# ip dhcp pool ForVLAN100
6. (dhcp-config)# network 10.10.10.0 255.255.255.0
7. (dhcp-config)# default-router 10.10.10.1
8. (dhcp-config)# dns-server 192.168.1.1
   (dhcp-config)# exit

9. (config)# ip dhcp excluded-address 10.10.10.1 10.10.10.100

10.(config)# service dhcp vlan 10
```

1. Configures VLAN 10 for connecting with AX3600S
2. Sets VLAN 10 to port 1/1
3. Assigns an IP address to the interface of VLAN 10
4. Sets a static route to the network under the switch AX3600S that requests DHCP service
5. Assigns the name "ForVLAN100" to the DHCP pool
6. Configures the network of the DHCP pool
7. Assigns the default route distributed by DHCP
8. Assigns the IP address of the DNS server that is distributed by DHCP
9. Assigns IP addresses that are excluded from the address distributed by DHCP
10. Configures VLAN to which DHCP service is provided (VLAN connected to the switch AX3600S in this example)

● AX3600S

```
1. (config)# vlan 10,100
   (config-vlan)# exit

2. (config)# interface gigabitethernet 0/1
   (config-if)# switchport mode access
   (config-if)# switchport access vlan 10
   (config-if)# exit

3. (config)# interface range gigabitethernet 0/11-24
   (config-if-range)# switchport mode access
   (config-if-range)# switchport access vlan 100
   (config-if-range)# exit

4. (config)# interface vlan 10
   (config-if)# ip address 192.168.1.2 255.255.255.0
   (config-if)# exit

   (config)# interface vlan 100
   (config-if)# ip address 10.10.10.1 255.255.255.0
5. (config-if)# ip helper-address 192.168.1.1
   (config-if)# exit
```

1. Configures VLAN 10 for connecting with the switch AX6700S and VLAN 100 for connecting the PC
2. Sets VLAN 10 to port 0/1
3. Sets VLAN 100 to ports 0/11 through 0/24
4. Assigns IP addresses to the VLAN interfaces
5. Assigns the IP address of the DHCP server in the VLAN interface that relays DHCP

[Operation command]

● AX6700S

[Status of DHCP allocation]

```
AX6708S# show ip dhcp binding
<IP address>      <MAC address>      <Lease expiration> <Type>
10.10.10.250      001a.4b7d.9980      09/01/28 15:29:49  Automatic
AX6708S#
AX6708S# show ip dhcp import
subnet 10.10.10.0 netmask 255.255.255.0
routers 10.10.10.1
domain-name-servers 192.168.1.1
AX6708S#
```

● AX6700S

[Status of DHCP server]

```
AX6708S# show ip dhcp server statistics
< DHCP Server use statistics >
address pools      :153
automatic bindings :1
manual bindings    :0
expired bindings   :0
over pools request :0
discard packets    :7
< Receive Packets >
BOOTREQUEST        :0
DHCPDISCOVER       :5
DHCPREQUEST        :4
DHCPDECLINE        :0
DHCPRELEASE        :0
DHCPINFORM         :0
< Send Packets >
BOOTREPLY          :0
DHCPPOFFER         :1
DHCPACK            :1
DHCPNAK            :0
AX6708S#
```

● AX3600S

[Gateway address of DHCP relay]

```
AX3630S# show dhcp giaddr all
DHCP GIADDR <vlan 100> : 10.10.10.1
AX3630S#
```

● AX3600S

[DHCP traffic statistics]

```

AX3630S# show dhcp traffic
<<Request Packets Count>>
<Number of Receive Packets> <Number of Send Packets>

| Receive Packets | Relay Address | Send Packets | Error Packets |
|-----------------|---------------|--------------|---------------|
| 9               | 192.168.1.1   | 9            | 0             |
| Total           |               | 9            | 0             |

<<Reply Packets Count>>
<Number of Receive Packets> <Number of Send Packets>

| Receive Packets | Send Packets | Error Packets |
|-----------------|--------------|---------------|
| 2               | 2            | 0             |



<<DHCP Packets Count>>
<Number of Discard Packets>
udp port number error : 0
ip header error : 0
giaddr error packets : 0
yiaddr error packets : 0
hops over packets : 0
not dhcp/bootp packets : 0
AX3630S#

```

3.2 NTP

This section describes a configuration example that uses the AX3600S series switch as an NTP client and server, along with the AX1200S series switch as an NTP client.

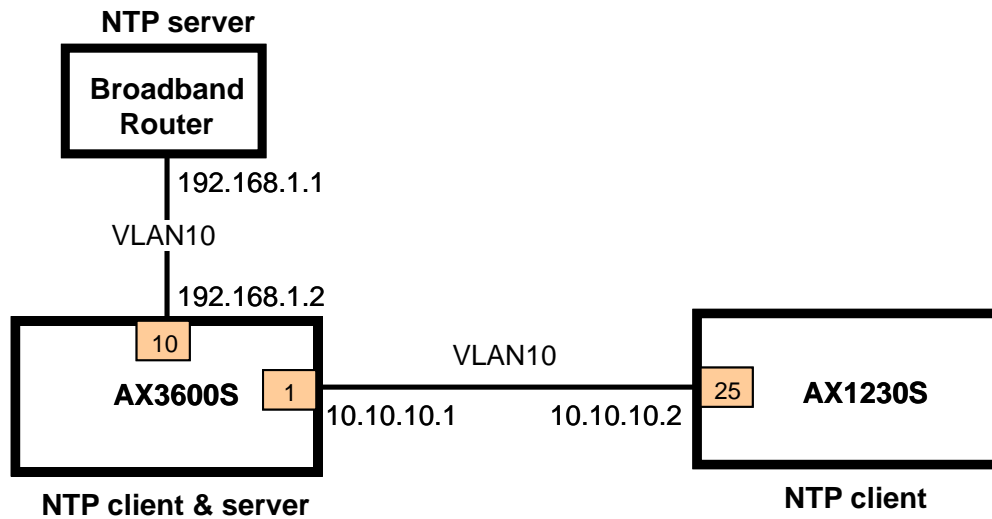
[Configuration figure]



[Explanation of the configuration figure]

The switch AX3600S is configured to operate as the NTP client of the broadband router and as the NTP server of the AX1200S series switch.

If you use an AX1240S series switch instead of an AX1230S series switch to build a configuration, replace the switch AX1230S in the configuration figure and in the explanation of the configuration figure with an AX1240S series switch.

[Configuration examples]

● AX3600S

```
1. (config)# vlan 10,100
   (config-vlan)# exit

2. (config)# interface gigabitethernet 0/1
   (config-if)# switchport mode access
   (config-if)# switchport access vlan 100
   (config-if)# exit

   (config)# interface gigabitethernet 0/10
   (config-if)# switchport mode access
   (config-if)# switchport access vlan 10
   (config-if)# exit

3. (config)# interface vlan 10
   (config-if)# ip address 192.168.1.2 255.255.255.0
   (config-if)# exit

   (config)# interface vlan 100
   (config-if)# ip address 10.10.10.1 255.255.255.0
   (config-if)# exit

4. (config)# ntp server 192.168.1.1
```

1. Configures VLAN 10 for access to BBR and VLAN 100 for communication with an AX1200S series switch
2. Sets VLAN 100 to port 0/1 and VLAN 10 to port 0/10
3. Assigns IP addresses to the VLAN interfaces
4. Assigns the IP address of an external server as the NTP server (a broadband router in this example) and configures the switch AX3600S so that it also operates as an NTP server

● AX1230S

```
1. (config)# vlan 100
   (config-vlan)# exit

2. (config)# interface gigabitethernet 0/25
   (config-if)# switchport mode access
   (config-if)# switchport access vlan 100
   (config-if)# media-type auto
   (config-if)# exit

3. (config)# interface vlan 100
   (config-if)# ip address 10.10.10.2 255.255.255.0
   (config-if)# exit

4. (config)# ntp client server 10.10.10.1
```

1. Configures VLAN 100 for access to the switch AX3600S
2. Sets VLAN 100 to port 0/25
3. Assigns an IP address to VLAN 100
4. Assigns the IP address of the switch AX3600S as the NTP server

● Differences in the configuration content between AX1230S series switches and AX1240S series switches

In the configuration content in this section, there is no difference between AX1230S series switches and AX1240S series switches.

[Operation command]

● AX3600S

[NTP status]

```
AX3630S# show ntp associations
      remote          refid          st t when poll reach  delay  offset  disp
=====
*192.168.1.1      xxx.xxx.xxx.xxx  2 u  22   64  377   1.37 -9616.3  3.73
AX3630S#
```

- Command execution result of show ntp associations command
xxx.xxx.xxx.xxx is the IP address of the NTP server.

● AX1230S

[NTP status]

```
AX1230S# show ntp-client

Date 2009/01/27 15:12:58 JST
Last NTP Status
  NTP-Server : 10.10.10.1, Source-Address : ---
  Mode : Unicast, Lapsed time : 1793(s), Offset : -118(s)

Activate NTP Client
  NTP-Server : 10.10.10.1, Source-Address : ---
  Mode : Unicast, Interval : 3600(s)

NTP Execute History(Max 10 entry)
  NTP-Server      Source-Address  Mode      Set-NTP-Time      Status
  10.10.10.1      ---             Unicast   2009/01/27 14:43:06  -118

AX1230S#
```

Appendix 1. Configuration Files

The following are the configuration files of the examples described in this document.

The text files of all the configurations for the switches are attached to this file.

(Adobe Acrobat 5.0 or later, or Adobe Acrobat Reader 6.0 or later, is required to extract the attached files.)

For each configuration, refer to the attached file for which the name is listed below:

1. Configuration examples of L2 functionalities

1.1 VLAN tunneling configuration files

1-01_VLAN_tunneling_config(AX6700S).txt
1-01_VLAN_tunneling_config(AX2400S).txt

1.2 Tag conversion configuration files

1-02_Tag_conversion_config(AX6700S).txt
1-02_Tag_conversion_config(AX2400S).txt

1.3 PVST+ configuration files

1-03_PVST_config(AX6300S).txt
1-03_PVST_config(AX2400S).txt
1-03_PVST_config(AX1230S).txt

1.4 PVST+ load-balancing configuration files

1-04_PVST_load_balancing_config(AX6300S).txt
1-04_PVST_load_balancing_config(AX2400S).txt
1-04_PVST_load_balancing_config(AX1230S).txt
1-04_PVST_load_balancing_config(AX1240S).txt

1.5 Spanning tree root guard configuration files

1-05_Spanning_tree_root_guard_config(AX6300S).txt
1-05_Spanning_tree_root_guard_config(AX2400S).txt
1-05_Spanning_tree_root_guard_config(AX1230S).txt
1-05_Spanning_tree_root_guard_config(AX1240S).txt

1.6 IGMP snooping configuration files

1-06_IGMP_snooping_config(AX6300S).txt
1-06_IGMP_snooping_config(AX2400S).txt
1-06_IGMP_snooping_config(AX1230S).txt
1-06_IGMP_snooping_config(AX1240S).txt

1.7 QoS configuration files

1-07_QoS_config(AX6300S).txt
1-07_QoS_config(AX2400S).txt
1-07_QoS_config(AX1230S).txt
1-07_QoS_config(AX1240S).txt

1.8 DHCP snooping configuration files

1-08_DHCP_snooping_config(AX6300S).txt
1-08_DHCP_snooping_config(AX2400S).txt
1-08_DHCP_snooping_config(AX1230S).txt
1-08_DHCP_snooping_config(AX1240S).txt

1.9 L2 loop detection configuration files

- 1-09_L2 loop detection_config(AX6300S).txt
- 1-09_L2 loop detection_config(AX2400S).txt
- 1-09_L2 loop detection_config(AX1230S).txt
- 1-09_L2 loop detection_config(AX1240S).txt

1.10 Storm control configuration files

- 1-10_Storm control_config(AX6300S)
- 1-10_Storm control_config(AX2400S)
- 1-10_Storm control_config(AX1230S)
- 1-10_Storm control_config(AX1240S)

1.11 Ring configuration files

- 1-11_Ring_config(AX6700S).txt
- 1-11_Ring_config(AX6300S).txt
- 1-11_Ring_config(AX2400S).txt

2. Configuration examples of L3 functionalities

2.1 RIP configuration files

- 2-01_RIP_config(AX6700S).txt
- 2-01_RIP_config(AX6300S).txt
- 2-01_RIP_config(AX3600S).txt

2.2 RIP filter configuration file

- 2-02_RIP filter_config(AX6700S).txt
- 2-02_RIP filter_config(AX6300S).txt
- 2-02_RIP filter_config(AX3600S).txt

2.3 OSPF configuration files

- 2-03_OSPF_config(AX6700S).txt
- 2-03_OSPF_config(AX6300S).txt
- 2-03_OSPF_config(AX3600S).txt

2.4 OSPF multiple-area configuration files

- 2-04_OSPF multiple areas_config(AX6700S).txt
- 2-04_OSPF multiple areas_config(AX6300S).txt
- 2-04_OSPF multiple areas_config(AX3600S).txt

2.5 VRRP configuration files

- 2-05_VRRP_config(AX6700S).txt
- 2-05_VRRP_config(AX6300S).txt
- 2-05_VRRP_config(AX3600S).txt
- 2-05_VRRP_config(AX2400S).txt

2.6 GSRP (L2/L3 linkage) configuration files

- 2-06_GSRP_config(AX6700S).txt
- 2-06_GSRP_config(AX6300S).txt
- 2-06_GSRP_config(AX3600S).txt
- 2-06_GSRP_config(AX2400S).txt

3. Configuration examples of other network functionalities

3.1 DHCP configuration files

3-01_DHCP_config(AX6700S).txt

3-01_DHCP_config(AX3600S).txt

3.2 NTP configuration files

3-02_NTP_config(AX3600S).txt

3-02_NTP_config(AX1230S).txt



Edition 1 issued on February 20, 2009

ALAXALA Networks Corporation

Shinkawasaki Mitsui Bldg West Tower 13F, 890
Kashimada, Saiwai-ku, Kawasaki-shi, Kanagawa
212-0058, Japan
<http://www.alaxala.com/en/>